

Canon

G600 series

ΞΕΚΙΝΩΝΤΑΣ

Příručka pro uvedení do provozu

Prvé spustenie

Pierwsze uruchomienie

Beüzemelési útmutató

Başlangıç Kılavuzu

Ghid de inițiere

Ръководство за начално запознаване

Navodila za postavitev in začetek uporabe

Početak

Διαβάστε πρώτα τις **Πληροφορίες για την ασφάλεια και σημαντικές πληροφορίες** (συμπλήρωμα).

Nejprve si přečtete **Informace o bezpečnosti a důležitá sdělení** (dodatek).

Najprv si prečítajte **Informácie o bezpečnosti a dôležité informácie** (dodatok).

Najpierw przeczytaj dodatek **Informacje o bezpieczeństwie i ważne uwagi**.

Először a (mellékelt) **Biztonsági és fontos tudnivalók** című dokumentumot olvassa el!

Önce **Güvenlik ve Önemli Bilgiler** başlıklı eki okuyun.

Citiți mai întâi **Informații cu privire la siguranță și alte informații importante** (anexă).

Прочетете най-напред **Информация за безопасността и важна информация** (приложение).

Najprej preberite **Informacije o varnosti in pomembne informacije** (dodatek).

Najprije pročitajte **Sigurnosne i važne informacije** (dodatak).



Q T 6 4 0 2 7 V 0 2



Εγκατάσταση του εκτυπωτή.....	σελίδα 1
Instalace tiskárny.....	str. 1
Inštalácia tlačiarne.....	strana 1
Instalowanie drukarki.....	strona 1
A nyomtató üzembe helyezésé.....	1. oldal
Yazıcıyı Kurma.....	sayfa 1
Instalarea imprimantei.....	pagina 1
Инсталиране на принтера.....	стр. 1
Namestitev tiskalnika.....	stran 1
Instaliranje pisača.....	stranica 1



Σύνδεση σε υπολογιστή, smartphone ή tablet.....	σελίδα 6
Připojení k počítači, chytrému telefonu nebo tabletu.....	str. 6
Pripojenie k počítaču, smartfónu alebo tabletu.....	strana 6
Podłączanie do komputera, smartfona lub tabletu.....	strona 6
Csatlakoztatás számítógéphez, okostelefonhoz vagy táblagéphez.....	6. oldal
Bilgisayara, Akıllı Telefona veya Tablete Bağlanma.....	sayfa 6
Conectarea la un computer, la un smartphone sau la o tabletă.....	pagina 6
Свързване с компютър, смартфон или таблет.....	стр. 6
Povezovanje z računalnikom, pametnim telefonom ali tabličnim računalnikom.....	stran 6
Povezivanje s računalnom, pametnim telefonom ili tabletom.....	stranica 6

Πώς να κρατήσετε τον εκτυπωτή

Jak tiskárnu držet

Ako držať tlačiareň

Trzymanie drukarki

Így kell megfogni a nyomtatót

Yazıcıyı Tutma

Ћinãnd imprimanta

Как да държите принтера

Držanje tiskalnika

Držanje pisača

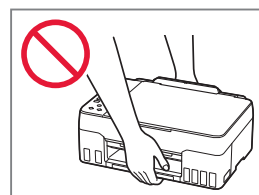
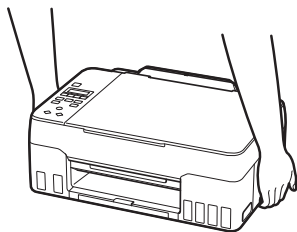



**Για την εγκατάσταση,
επισκεφθείτε το URL
<https://ij.start.canon>**



ή σαρώστε τον κωδικό με την κινητή συσκευή σας

• Ακολουθήστε τις παρακάτω οδηγίες αν δεν έχετε σύνδεση internet.

1. Περιεχόμενα συσκευασίας

• Κεφαλές εκτύπωσης

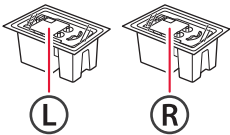

- Φιάλες μελάνης
- Καλώδιο τροφοδοσίας
- CD-ROM εγκατάστασης
- Πληροφορίες για την ασφάλεια και σημαντικές πληροφορίες
- Ξεκινώντας (αυτό το χειρίδιο)

2. Αφαίρεση υλικών συσκευασίας



- 1 Αφαιρέστε και απορρίψτε τυχόν υλικά συσκευασίας και πορτοκαλί ταινία.
- 2 Ανοίξτε τη μονάδα σάρωσης / κάλυμμα, αφαιρέστε και απορρίψτε την πορτοκαλί ταινία και το προστατευτικό υλικό από το εσωτερικό.

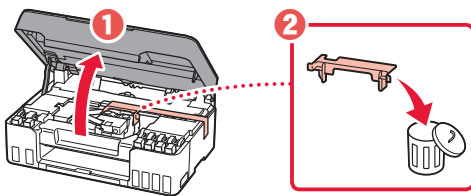

3. Εγκατάσταση των κεφαλών εκτύπωσης



- 1 Ανοίξτε το κάλυμμα ασφάλισης κεφαλής εκτύπωσης.

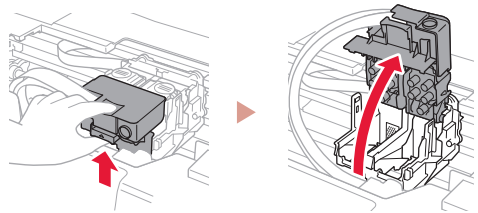

- 2 Βγάλτε κάθε κεφαλή εκτύπωσης από τη συσκευασία και αφαιρέστε την ετικέτα.

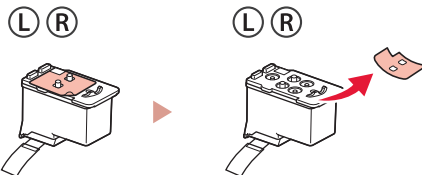

- 3 Αφαιρέστε την πορτοκαλί ταινία.

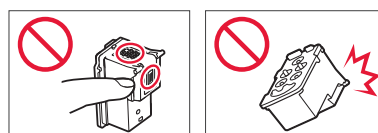
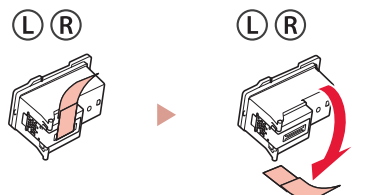

Ρύθμιση του εκτυπωτή

- 4 Τοποθετήστε την κεφαλή εκτύπωσης L στα αριστερά και την κεφαλή εκτύπωσης R στα δεξιά.

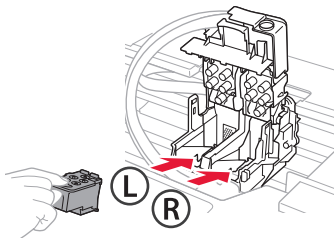

- 5 Κλείστε το κάλυμμα ασφάλισης κεφαλής εκτύπωσης και πιέστε το προς τα κάτω μέχρι να κάνει κλικ.

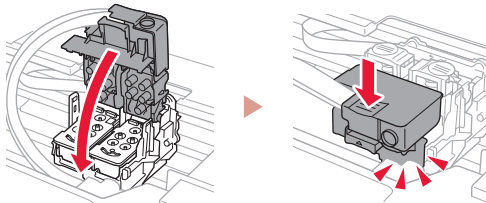

- 6 Πιέστε προς τα κάτω και τα δύο κουμπιά αρμού εντελώς μέχρι να κάνουν κλικ.

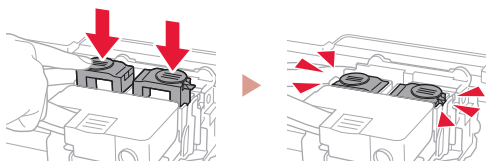

Ελέγξτε!

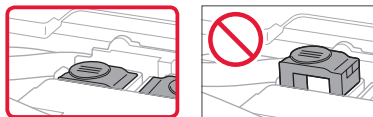

- 7 Κλείστε τη μονάδα σάρωσης / κάλυμμα.
- Ανοίξτε πλήρως τη μονάδα σάρωσης / κάλυμμα και, έπειτα, κλείστε τη.

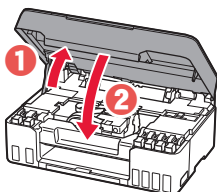

⚠ Προσοχή
Προσέχετε τα δάχτυλά σας.

4. Ενεργοποίηση του εκτυπωτή



- 1 Συνδέστε το καλώδιο τροφοδοσίας.

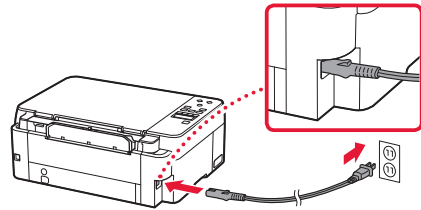

Πίσω μέρος

- 2 Πατήστε το κουμπί **ON**.

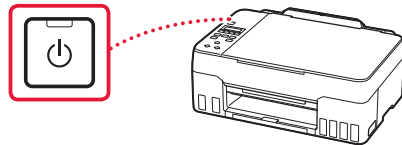

- 3 Όταν εμφανιστεί η ακόλουθη οθόνη, χρησιμοποιήστε τα κουμπιά ◀ και ▶ για να επιλέξετε γλώσσα, και, στη συνέχεια, πατήστε το κουμπί **OK**.



»»» Σημαντικό

Αν εμφανιστεί σφάλμα στην οθόνη, ανατρέξτε στην ενότητα «Αν εμφανιστεί μήνυμα σφάλματος (κωδικός υποστήριξης) στην οθόνη» στη σελίδα 5 και ακολουθήστε τις οδηγίες.

5. Άδειασμα μελάνης



»»» Σημαντικό

Αυτό το προϊόν απαιτεί προσεκτικό χειρισμό της μελάνης. Ενδέχεται να πεταχτεί μελάνη όταν τα δοχεία μελάνης είναι γεμάτα. Εάν τα ρούχα σας ή κάποιο αντικείμενο λερωθούν με μελάνη, μπορεί να μην καθαρίσουν.

1 Ανοίξτε τη μονάδα σάρωσης / κάλυμμα.

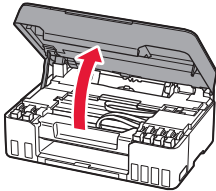

2 Ανοίξτε το γκρι κάλυμμα δοχείου στα αριστερά του εκτυπωτή.

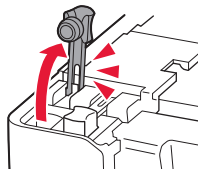

3 Κρατήστε τη GY (γκρι) φιάλη μελάνης όρθια και γυρίστε απαλά το κάλυμμα φιάλης για να το αφαιρέσετε.

Ελέγξτε!

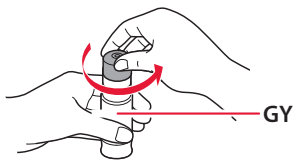

4 Ευθυγραμμίστε το ακροφύσιο της φιάλης μελάνης με το σημείο εισροής.

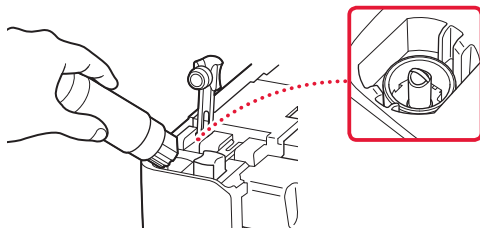

5 Κρατήστε αργά τη φιάλη μελάνης ανάποδα και πιέστε προς τα κάτω για να χυθεί η μελάνη.

- Αν δεν χυθεί η μελάνη, αφαιρέστε απαλά τη φιάλη μελάνης και προσπαθήστε ξανά.

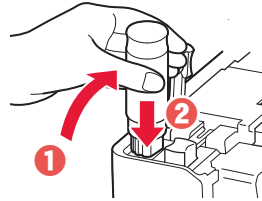

6 Αφαιρέστε απαλά τη φιάλη μελάνης από το σημείο εισροής.

- Προσέξτε να μη χυθεί η μελάνη.

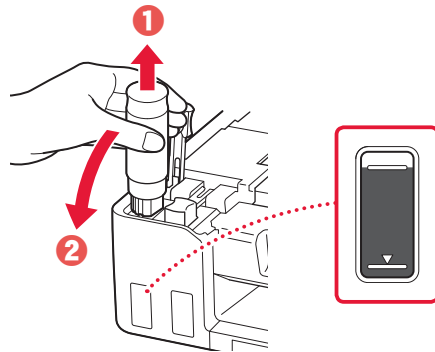

7 Τοποθετήστε ξανά το κάλυμμα δοχείου με ασφάλεια.

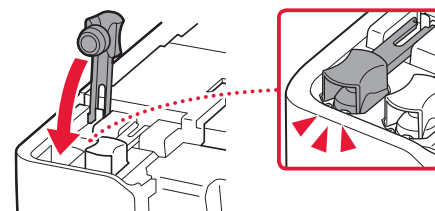

Ρύθμιση του εκτυπωτή

8 Επαναλάβετε τα βήματα 2 έως 7 για να αδειάσετε όλη την ποσότητα μελάνης για όλα τα χρώματα στα δοχεία μελάνης για κάθε χρώμα.

- Αδειάστε την παρεχόμενη μελάνη που ταιριάζει με το χρώμα του καλύμματος δοχείου.

Ελέγξτε!

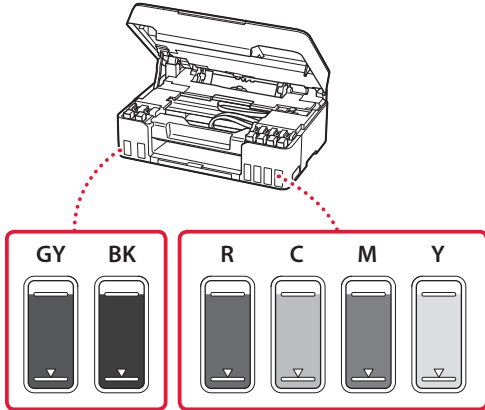

9 Κλείστε τη μονάδα σάρωσης / κάλυμμα.

- Ανοίξτε πλήρως τη μονάδα σάρωσης / κάλυμμα και, έπειτα, κλείστε τη.

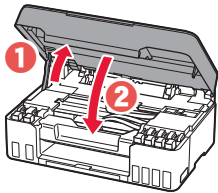

⚠ Προσοχή

Προσέχετε τα δάχτυλά σας.

10 Χρησιμοποιήστε τα κουμπιά ◀ και ▶ για να επιλέξετε **Ναι (Yes)** και, στη συνέχεια, πατήστε το κουμπί **OK**.

Are the ink tanks filled w
 Yes < No >

6. Τοποθέτηση χαρτιού



1 Χρησιμοποιήστε τα κουμπιά ◀ και ▶ για να επιλέξετε **Ναι (Yes)** και, στη συνέχεια, πατήστε το κουμπί **OK**.

Start alignment to impro
 Yes > No

2 Εκτείνετε την υποστήριξη χαρτιού.

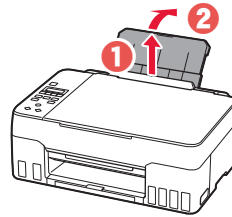

3 Ανοίξτε το κάλυμμα υποδοχής τροφοδοσίας και σύρετε το δεξιό οδηγό χαρτιού προς τα δεξιά έως το τέρμα.

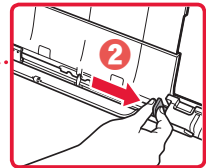
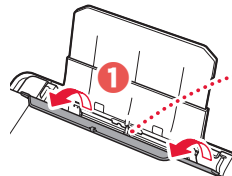

4 Τοποθετήστε χαρτί.

- Τοποθετήστε 2 ή περισσότερες σελίδες απλού χαρτιού μεγέθους Letter ή A4.
- Σύρετε τον πλευρικό οδηγό χαρτιού στην άκρη της στοίβας χαρτιών.

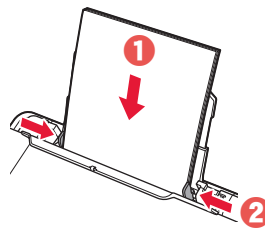

5 Κλείστε το κάλυμμα υποδοχής τροφοδοσίας.

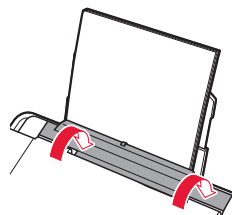

6 Εκτείνετε τη θήκη εξόδου χαρτιού.

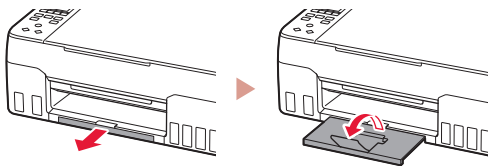

7 Ακολουθήστε τις οδηγίες στην οθόνη και, στη συνέχεια, πατήστε το κουμπί **OK**.

Load 2 or more sheets of
[OK]Next

Adjusting for first use...
About █ min. remaining

- Περιμένετε λίγο μέχρι να εμφανιστεί η ακόλουθη οθόνη.

Do you want to update at
< Yes > No

Setup is complete
[OK]

To connect to a computer
[OK]

Copy
100% █ 01

Επιλέξτε τη μέθοδο που ταιριάζει καλύτερα στον τρόπο που θα χρησιμοποιείτε τον εκτυπωτή.

- Για χρήση του εκτυπωτή χωρίς σύνδεση σε άλλες συσκευές
➔ Η ρύθμιση έχει ολοκληρωθεί.
- Για χρήση του εκτυπωτή με σύνδεση σε υπολογιστή ή smartphone
➔ Προχωρήστε στην επόμενη σελίδα.

? Αν εμφανιστεί μήνυμα σφάλματος (κωδικός υποστήριξης) στην οθόνη

Protective material rema
Support code 1890

Κωδ. υποστήρ.
(Support code)

Ελέγξτε τον κωδικό υποστήριξης και στη συνέχεια ακολουθήστε τις οδηγίες εάν ο εμφανιζόμενος κώδικας είναι γραμμένος παρακάτω.

- **1890**
Προστατευτικό υλικό που απομένει.
➔ «2. Αφαίρεση υλικών συσκευασίας» στη σελίδα 1
- **1470/1471**
Οι κεφαλές εκτύπωσης δεν έχουν τοποθετηθεί σωστά.
➔ «3. Εγκατάσταση των κεφαλών εκτύπωσης» στη σελίδα 1
- **1474**
Οι κεφαλές εκτύπωσης δεν έχουν τοποθετηθεί σωστά.
Κλείστε τον μοχλό βαλβίδας μελάνης και ανταλλάξτε την αριστερή και δεξιά κεφαλή εκτύπωσης.

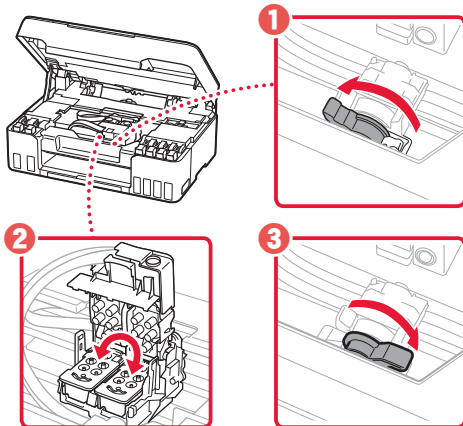

➔ «3. Εγκατάσταση των κεφαλών εκτύπωσης» στη σελίδα 1

- **5200**
Η προετοιμασία του συστήματος μελάνης δεν ολοκληρώθηκε επιτυχώς.
Πατήστε το κουμπί **ON** για να κάνετε επανεκκίνηση του εκτυπωτή και, στη συνέχεια, ανατρέξτε στην ενότητα «5. Άδειασμα μελάνης» στη σελίδα 3.

Για όλες τις λοιπές περιπτώσεις, ανατρέξτε στο **Online εγχειρίδιο**.

Τι συσκευή σκοπεύετε να συνδέσετε;



Υπολογιστής



Υπολογιστής και
smartphone



Smartphone

7-a

Σύνδεση με υπολογιστή

Εάν χρησιμοποιείτε πολλούς υπολογιστές, εκτελέστε αυτά τα βήματα σε κάθε υπολογιστή.



- 1 Μεταβείτε στη διαδικτυακή τοποθεσία της Canon από τον υπολογιστή σας.
 <https://ij.start.canon>
- 2 Επιλέξτε  **Εγκατάσταση**.
- 3 Καταχωρίστε το όνομα μοντέλου του εκτυπωτή σας και κάντε κλικ στην επιλογή **Μετάβαση**.
- 4 Κάντε κλικ στο **Έναρξη**.
- 5 Κάντε κλικ στο **(B) Σύνδεση σε υπολογιστή/smartphone**.
 - Τα παρακάτω βήματα αφορούν τους χρήστες Windows.
- 6 Κάντε κλικ στο **Λήψη**.
- 7 Εκτελέστε το ληφθέν αρχείο.
 - Ακολουθήστε τις οδηγίες στην οθόνη. Αυτό ενδέχεται να χρειαστεί κάποιο χρόνο.
 - Για να συνδέσετε και σε smartphone, ανατρέξτε στην ενότητα «7-b. Σύνδεση με Smartphone» στη σελίδα 7.



Χρήση του CD-ROM εγκατάστασης

Κάντε διπλό κλικ στο αρχείο **EasySetup.exe** που υπάρχει στο CD-ROM και, έπειτα, συνεχίστε από το βήμα 3. Αν δεν έχετε σύνδεση internet, ανοίξτε το φάκελο **win** στο CD-ROM και κάντε διπλό κλικ στο αρχείο **SETUP.exe**. Αυτή η ενέργεια θα εγκαταστήσει το πρόγραμμα οδήγησης του εκτυπωτή.

7-b

Σύνδεση με Smartphone

Εάν χρησιμοποιείτε πολλά smartphone, εκτελέστε αυτά τα βήματα σε κάθε smartphone.



1 Εγκαταστήστε την εφαρμογή «Canon PRINT Inkjet/SELPHY» στο smartphone σας.



- Κάντε αναζήτηση για το «Canon PRINT» στο App Store ή στο Google Play.
- Μεταβείτε στη διαδικτυακή τοποθεσία της Canon για λήψη της εφαρμογής.



2 Ανοίξτε τις ρυθμίσεις Wi-Fi του smartphone σας. Ελέγξτε ότι εμφανίζεται το όνομα δικτύου (SSID) που ξεκινά με «Canon_ij_».

(Παράδειγμα της οθόνης iOS)

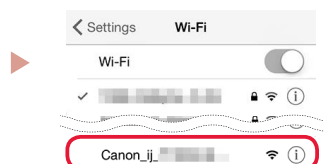

Το όνομα δικτύου (SSID) που ξεκινά με «Canon_ij_»

- Αν εμφανιστεί το «Canon_ij_» → Προχωρήστε στο βήμα **3**.
- Αν δεν εμφανιστεί το «Canon_ij_» → Προχωρήστε στο βήμα **4**.

3 Πατήστε το όνομα δικτύου (SSID) που ξεκινά με «Canon_ij_».

4 Ανοίξτε την εγκατεστημένη εφαρμογή και ακολουθήστε τις οδηγίες που εμφανίζονται στην οθόνη στην εφαρμογή για να προσθέσετε τον εκτυπωτή σας.

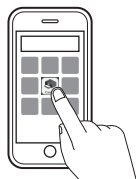

Αφού προσθέσετε τον εκτυπωτή σας, θα μπορείτε να εκτυπώνετε από το smartphone σας. Για να εκτυπώσετε φωτογραφίες, ανατρέξτε στην ενότητα «Τοποθέτηση φωτογραφικού χαρτιού» στη σελίδα 8.

Τοποθέτηση φωτογραφικού χαρτιού

- 1 Εκτείνετε την υποστήριξη χαρτιού.

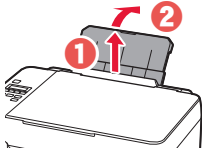

- 2 Ανοίξτε το κάλυμμα υποδοχής τροφοδοσίας και σύρετε το δεξιό οδηγό χαρτιού προς τα δεξιά έως το τέρμα.

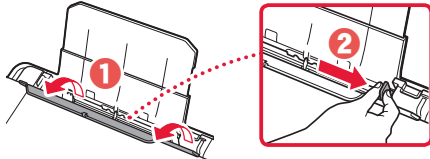

- 3 Τοποθετήστε πολλά φύλλα φωτογραφικού χαρτιού με την πλευρά εκτύπωσης στραμμένη προς τα πάνω και σύρετε τον πλαϊνό οδηγό χαρτιού στην άκρη της στοίβας χαρτιών.

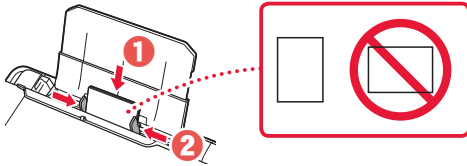

- 4 Κλείστε το κάλυμμα υποδοχής τροφοδοσίας.

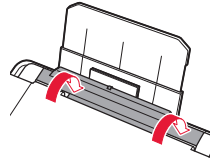

- 5 Όταν εμφανίζεται το μήνυμα **Καταχωρίστε τις πληροφορίες χαρτιού για την πίσω θήκη (Save the rear tray paper information)** στην οθόνη του εκτυπωτή, πατήστε το κουμπί **OK**.

- 6 Επιλέξτε το μέγεθος και τον τύπο χαρτιού και, στη συνέχεια, πατήστε το κουμπί **OK**.

- 7 Εκτείνετε τη θήκη εξόδου χαρτιού.

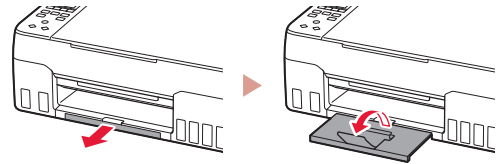

Μεταφορά του εκτυπωτή σας

Κατά τη μετακίνηση του εκτυπωτή, ελέγξτε τα παρακάτω. Ανατρέξτε στο **Online εγχειρίδιο** για λεπτομέρειες.

Ελέγξτε ότι και τα δύο κουμπιά αρμού είναι εντελώς πιεσμένα κάτω για να αποφύγετε διαρροές μελάνης.

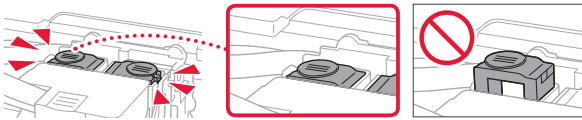

Ελέγξτε ότι η θέση του μοχλού βαλβίδας μελάνης είναι κλειστή.

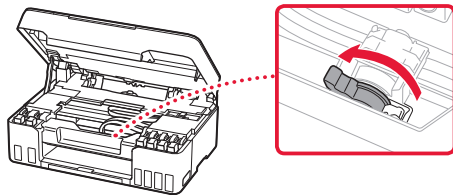

Συσκευάστε τον εκτυπωτή σε μια πλαστική τσάντα σε περίπτωση που διαρρέψει μελάνη.

- Συσκευάστε τον εκτυπωτή σε ένα ανθεκτικό κιβώτιο ώστε η κάτω πλευρά του να τοποθετηθεί στον πάτο του κιβωτίου, χρησιμοποιώντας επαρκή ποσότητα προστατευτικού υλικού για την ασφαλή μεταφορά του.
- Μην γείρετε τον εκτυπωτή. Μπορεί να διαρρέψει μελάνη.
- Δείξτε προσοχή κατά το χειρισμό και φροντίστε η συσκευασία να είναι όρθια και ΟΧΙ ανάποδα ή στο πλάι, καθώς μπορεί να προκληθεί βλάβη στον εκτυπωτή και διαρροή μελάνης.
- Κατά τη μεταφορά του εκτυπωτή από κάποια εταιρεία μεταφορών, φροντίστε να επισημάνετε το κιβώτιο με την ένδειξη «ΑΥΤΗ Η ΠΛΕΥΡΑ ΕΠΙΛΕΞΤΕ» για να παραμείνει η κάτω πλευρά του εκτυπωτή στον πάτο του κιβωτίου. Προσθέστε επίσης τις επισημάνσεις «ΕΥΘΡΑΥΣΤΟ» ή «ΠΡΟΣΕΚΤΙΚΟΣ ΧΕΙΡΙΣΜΟΣ».

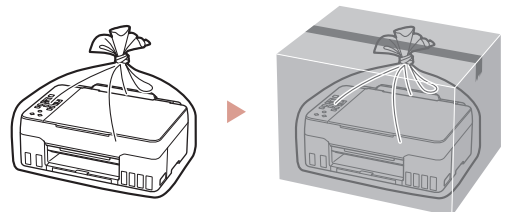

Nastavení tiskárny



K nastavení použijte adresu URL

<https://ij.start.canon>



nebo naskenujte kód pomocí svého mobilního zařízení

● Pokud nemáte přístup k internetu, postupujte podle následujících pokynů.

1. Obsah balení

● Tiskové hlavy

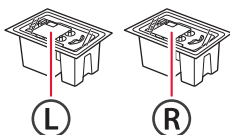

- Láhve na inkoust
- Napájecí kabel
- Instalační disk CD-ROM
- Informace o bezpečnosti a důležitá sdělení
- Příručka pro uvedení do provozu (tato příručka)

2. Odstranění ochranného materiálu



- 1 Odstraňte a zahodte veškeré obalové materiály a oranžovou pásku.
- 2 Otevřete skener / kryt, odstraňte a zahodte oranžovou pásku a ochranný materiál, který se nachází uvnitř.

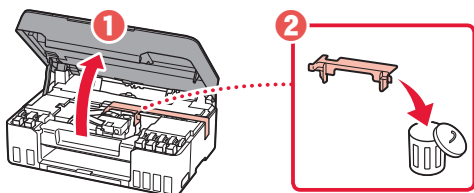

3. Instalace tiskových hlav



- 1 Otevřete zajišťovací kryt tiskové hlavy.

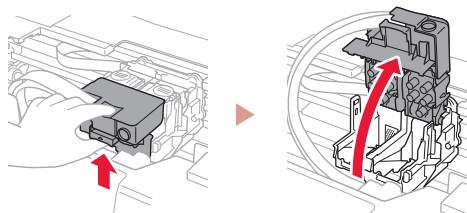

- 2 Vyměňte jednotlivé tiskové hlavy z obalu a odstraňte jejich etikety.

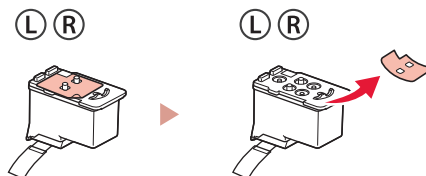

- 3 Odstraňte oranžovou pásku.

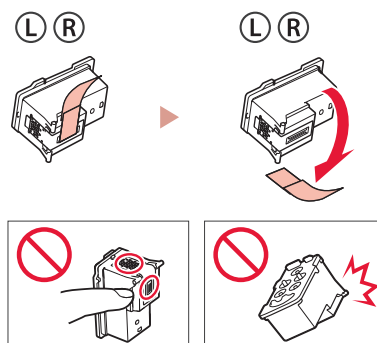

Nastavení tiskárny

- 4 Vložte tiskovou hlavu L vlevo a tiskovou hlavu R vpravo.

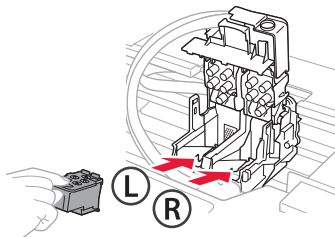

- 5 Zavřete zajišťovací kryt tiskové hlavy a zatlačte jej, až zaklapne na své místo.

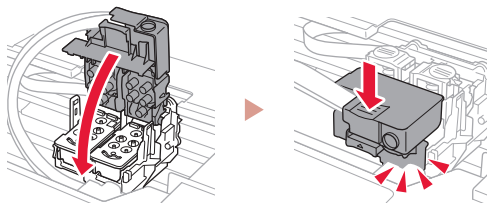

- 6 Stiskněte obě tlačítka pro spojení zcela dolů, dokud neuslyšíte cvaknutí.

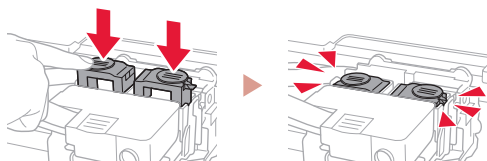

Nezapomeňte zkontrolovat!

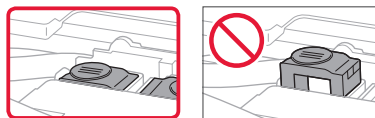

- 7 Zavřete skener / kryt.
- Úplně otevřete skener / kryt a následně jej zavřete.

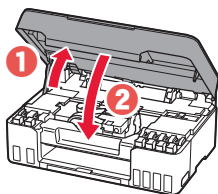

⚠ Upozornění
Neskřípněte si prsty.

4. Zapnutí tiskárny



- 1 Připojte napájecí kabel.

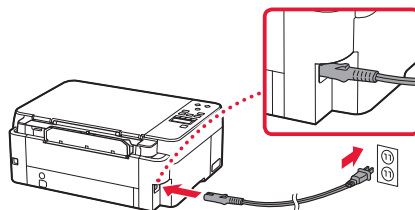

Zadní strana

- 2 Stiskněte tlačítko **ZAPNOUT (ON)**.

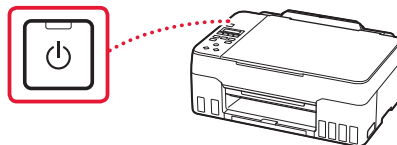

- 3 Pokud se zobrazí následující obrazovka, vyberte jazyk pomocí tlačítka ◀ a ▶ a poté stiskněte tlačítko **OK**.



»»» Důležité

Pokud se na obrazovce objeví chyba, přejděte k části „Pokud se na obrazovce zobrazí chybová zpráva (kód podpory)“ na str. 5 a postupujte podle pokynů.

5. Nalítí inkoustu



»»» Důležité

Tento produkt vyžaduje opatrnou manipulaci s inkoustem. Při naplňování nádržek s inkoustem může dojít k potřísnění inkoustem. Pokud se inkoust dostane na váš oděv nebo další předměty, může je nevratně zbarvit.

1 Otevřete skener / kryt.

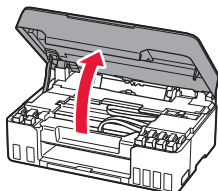

2 Otevřete šedou krytku nádržky v levé části tiskárny.

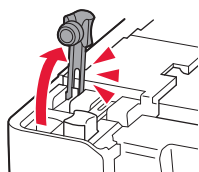

3 Láhev na inkoust GY (šedá) držte vzpřímeně a lehkým otáčením sejměte krytku láhve.

Nezapomeňte zkontrolovat!

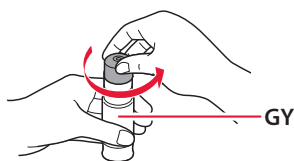

4 Zarovnejte trysku láhve na inkoust s přívodem.

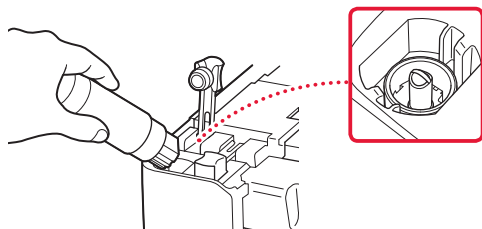

5 Pomalu láhev na inkoust narovnejte, aby byla dnem nahoru, zatlačte na ni a nalijte inkoust.

- Pokud inkoust nevytéká, láhev na inkoust vyjměte a akci opakujte.

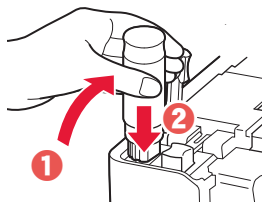

6 Láhev na inkoust opatrně vyjměte z přívodu.

- Manipulujte s ní opatrně, aby se inkoust nevylil.

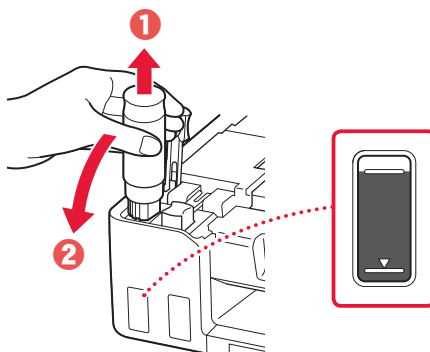

7 Bezpečně nasadte krytku nádržky.

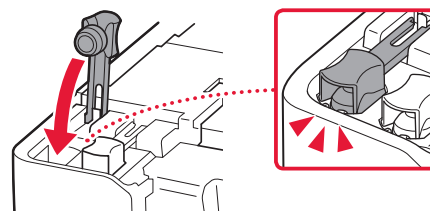

Nastavení tiskárny

- 8 Zopakováním kroků 2 až 7 nalijte veškerý inkoust do odpovídajících nádržek s inkoustem jednotlivých barev.

- Nalijte dodaný inkoust, který odpovídá barvě krytky nádržky.

Nezapomeňte zkontrolovat!

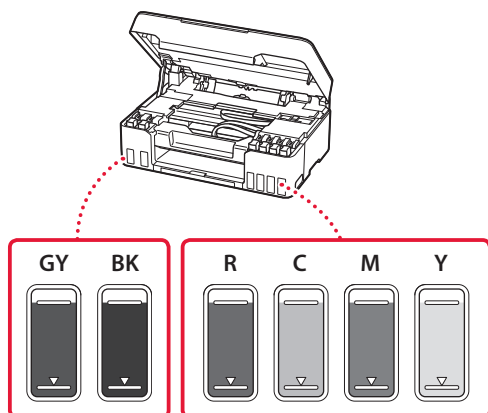

- 9 Zavřete skener / kryt.

- Úplně otevřete skener / kryt a následně jej zavřete.

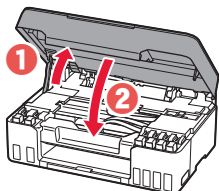

⚠ Upozornění
Neskřípněte si prsty.

- 10 Pomocí tlačítek ◀ a ▶ vyberte možnost **Ano (Yes)** a stiskněte tlačítko **OK**.

Are the ink tanks filled w
 Yes < No >

6. Vložení papíru



- 1 Pomocí tlačítek ◀ a ▶ vyberte možnost **Ano (Yes)** a stiskněte tlačítko **OK**.

Start alignment to impro
 Yes > No

- 2 Vysuňte opěrku papíru.

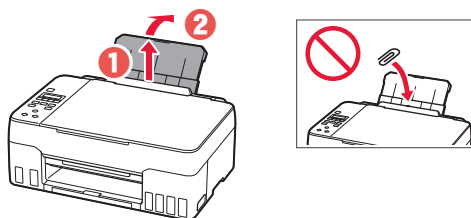

- 3 Otevřete kryt otvoru podavače a posuňte pravé vodítko papíru zcela doprava.

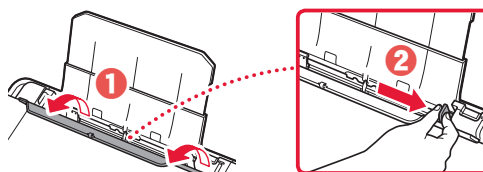

- 4 Vložte papír.

- Vložte 2 nebo více listů běžného papíru formátu Letter nebo A4.
- Posuňte boční vodítko papíru na hranu stohu papíru.

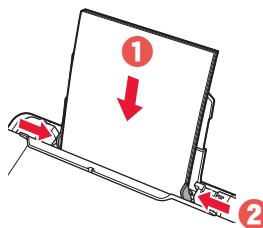

- 5 Zavřete kryt otvoru podavače.

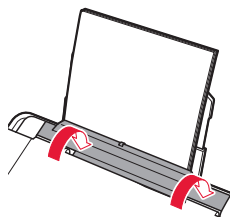

6 Vysuňte výstupní zásobník na papír.

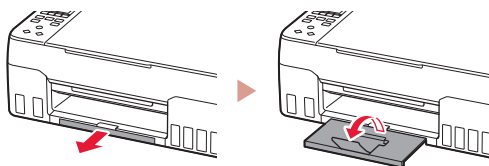

7 Postupujte podle pokynů na obrazovce a stiskněte tlačítko OK.

Load 2 or more sheets of
[OK]Next

Adjusting for first use...
About █ min. remaining

- Chvilí počkejte, dokud se neotevře následující obrazovka.

Do you want to update at
< Yes > No

Setup is complete
[OK]

To connect to a computer
[OK]

Copy
100% █ 01

Vyberte metodu připojení, která nejlépe vyhovuje zamýšlenému způsobu používání tiskárny.

- Používání tiskárny bez připojení k dalším zařízením
➔ Nastavení je tímto dokončeno.
- Používání tiskárny s připojeným počítačem nebo chytrým telefonem
➔ Pokračujte na další stránce.

? Pokud se na obrazovce zobrazí chybová zpráva (kód podpory)

Protective material rema
Support code 1890

Kód podpory
(Support code)

Zkontrolujte kód podpory a postupujte podle pokynů, pokud je zobrazený kód uvedený níže.

- 1890
Neodstranili jste veškerý ochranný materiál.
➔ „2. Odstranění ochranného materiálu“ na str. 1
- 1470/1471
Tiskové hlavy nejsou nainstalovány správně.
➔ „3. Instalace tiskových hlav“ na str. 1
- 1474
Tiskové hlavy nejsou nainstalovány správně.
Zavřete páčku ventilu inkoustu a zaměřte levou a pravou tiskovou hlavu.

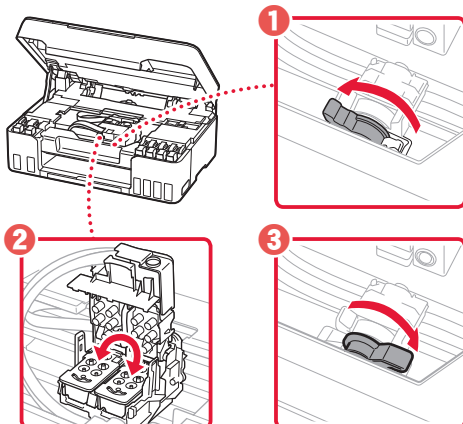

➔ „3. Instalace tiskových hlav“ na str. 1

- 5200
Příprava inkoustového systému nebyla úspěšně dokončena.
Stisknutím tlačítka **ZAPNOUT (ON)** tiskárnu restartujte a další postup vyhledejte v části „5. Nalítí inkoustu“ na str. 3.

Ve všech ostatních případech si přečtěte dokument **Příručka online**.

Jaké zařízení chcete připojit?



Počítač



Počítač a chytrý telefon



Chytrý telefon

7-a

Připojení k počítači

Pokud používáte několik počítačů, bude nutné přípravu provést na každém z nich.



- 1 V počítači otevřete webovou stránku Canon.
 <https://ij.start.canon>
- 2 Vyberte možnost  **Nastavení**.
- 3 Zadejte název modelu vaší tiskárny a klepněte na tlačítko **Přejít**.
- 4 Klepněte na tlačítko **Start**.
- 5 Klepněte na tlačítko **(B) Připojení k počítači / chytrému telefonu**.
 - Následující kroky platí pro uživatele systému Windows.
- 6 Klepněte na tlačítko **Stáhnout**.
- 7 Spusťte stažený soubor.
 - Postupujte podle pokynů na obrazovce. Dokončení může chvíli trvat.
 - Návod pro připojení k chytrému telefonu naleznete na stránce „7-b. Připojení k chytrému telefonu“ na str. 7.



Používání instalačního disku CD-ROM

V možnostech disku CD-ROM poklepejte na možnost **EasySetup.exe** a poté pokračujte od kroku 3. Pokud nemáte připojení k internetu, otevřete složku **win** na instalačním disku CD-ROM a dvojklikněte na **SETUP.exe**. Spustí se instalace ovladače tiskárny.

7-b

Připojení k chytrému telefonu

Pokud používáte několik chytrých telefonů, bude nutné přípravu provést na každém z nich.



1 Ve svém chytrém telefonu nainstalujte aplikaci „Canon PRINT Inkjet/SELPHY“.



- V obchodě App Store nebo Google Play vyhledejte aplikaci „Canon PRINT“.
- Přejděte na webovou stránku Canon a stáhněte si aplikaci.



2 Otevřete nastavení svého chytrého telefonu Wi-Fi. Ujistěte se, že se zobrazil název sítě (SSID) začínající na „Canon_ij_“.

(Příklad obrazovky iOS)

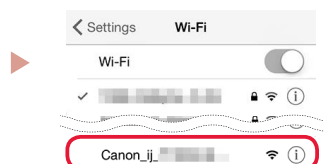

Název sítě (SSID), který začíná na „Canon_ij_“

- Pokud se zobrazí název „Canon_ij_“, → přejděte ke kroku **3**.
- Pokud se název „Canon_ij_“ nezobrazí, → přejděte ke kroku **4**.

3 Klepněte na název sítě (SSID), který začíná na „Canon_ij_“.

4 Otevřete nainstalovanou aplikaci a poté podle pokynů na obrazovce aplikace přidejte svou tiskárnu.



Jakmile přidáte svou tiskárnu, můžete na ní tisknout z chytrého telefonu.

Postup tisku fotografií najdete v části „Vložení fotografického papíru“ na str. 8.

Vložení fotografického papíru

1 Vysuňte opěrku papíru.

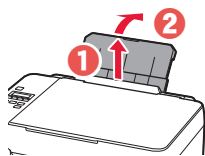

2 Otevřete kryt otvoru podavače a posuňte pravé vodítko papíru zcela doprava.

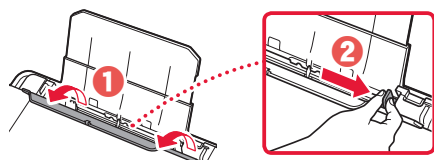

3 Vložte několik listů fotografického papíru tiskovou stranou nahoru a přitiskněte pravé vodítko papíru ke stohu papíru.

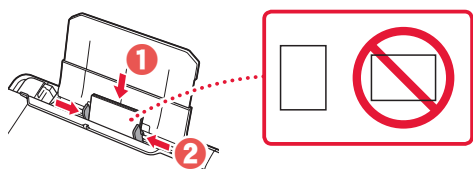

4 Zavřete kryt otvoru podavače.

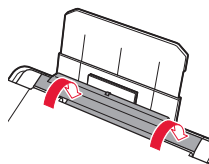

5 Když se na obrazovce tiskárny zobrazí zpráva s textem **Zaregistrovat informace o papíru v zadní přihrádce (Save the rear tray paper information)**, stiskněte tlačítko **OK**.

6 Vyberte velikost a typ papíru a stiskněte tlačítko **OK**.

7 Vysuňte výstupní zásobník na papír.

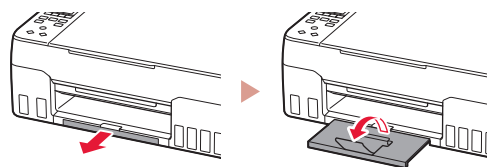

Přeprava tiskárny

Při přepravě tiskárny dodržujte tyto pokyny. Podrobné informace naleznete v dokumentu **Příručka online**.

Zkontrolujte, zda jsou obě tlačítka pro spojení zatlačena zcela dolů, aby neunikl inkoust.

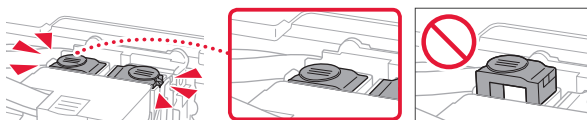

Ujistěte se, že páčka ventilu inkoustu je v uzavřené poloze.

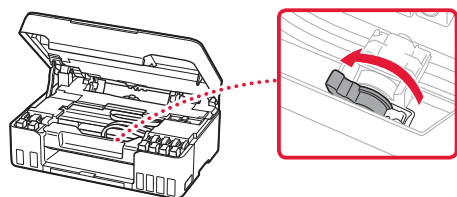

Tiskárnu zabalte do plastického pytle pro případ, že by z ní unikl inkoust.

- Zabalte tiskárnu do pevné krabice tak, aby byla umístěna dnem dolů. Použijte dostatečné množství ochranného materiálu, aby přeprava byla bezpečná.
- Tiskárnu nenaklánějte. Může dojít k úniku inkoustu.
- Při manipulaci postupujte obezřetně a dbejte na to, aby balení zůstávalo vždy ve správné poloze, tedy NE hlavou dolů nebo na boku. V opačném případě hrozí poškození tiskárny a únik inkoustu v tiskárně.
- Pokud odesíláte tiskárnu prostřednictvím pošty nebo jiného přepravce, označte balík nápisem „TOUTO STRANOU NAHORU“. Zajistíte tak přepravu tiskárny v poloze dnem dolů. Dodejte také označení „KŘEHKÉ“ nebo „OPATRNĚ“.

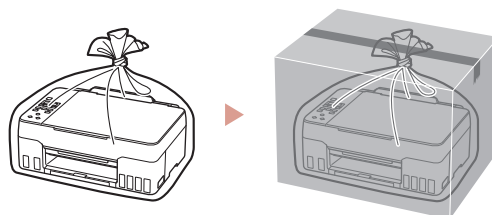

Nastavenie tlačiarne



Ak chcete vykonať nastavenie, navštívte adresu URL

<https://ij.start.canon>



alebo naskenujte kód pomocou svojho mobilného zariadenia

● Ak nemáte pripojenie k internetu postupujte podľa pokynov nižšie.

1. Obsah balenia

● Tlačové hlavy

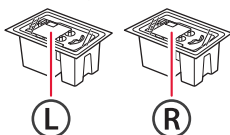

- Fľaše s atramentom
- Napájací kábel
- Inštalačný disk
- Informácie o bezpečnosti a dôležité informácie
- Prvé spustenie (táto príručka)

2. Odstránenie obalového materiálu



- 1 Z tlačiarne odstráňte a zahodte obalový materiál a oranžovú pásku.
- 2 Otvorte skenovaciu jednotku/kryt, odstráňte a zahodte oranžovú pásku a vnútorný ochranný materiál.

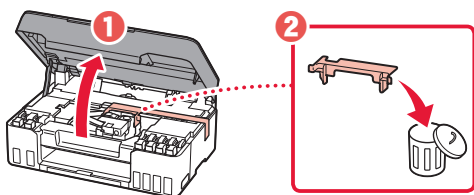

3. Vkladanie tlačových hláv



- 1 Otvorte zaistovací kryt tlačovej hlavy.

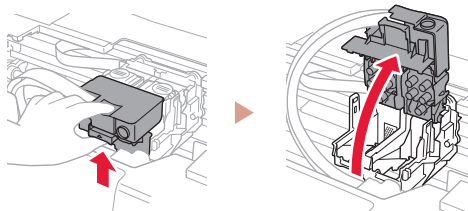

- 2 Z balenia vyberte jednotlivé tlačové hlavy a odstráňte ich štítky.

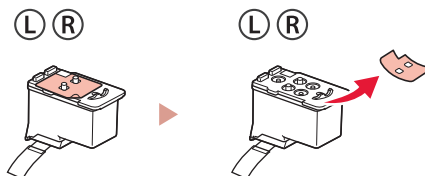

- 3 Odstráňte oranžovú pásku.

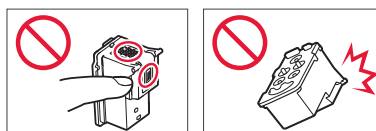
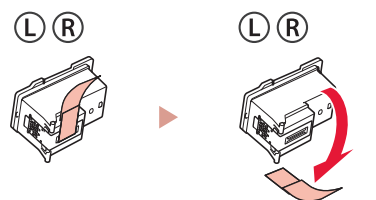

Nastavenie tlačiarne

- 4 Zasuňte L tlačovú hlavu na ľavej strane a R tlačovú hlavu na pravej strane.

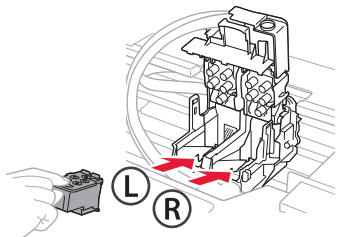

- 5 Zatvorte zaistovací kryt tlačovej hlavy a zatlačte ho nadol, kým nezačujete cvaknutie.

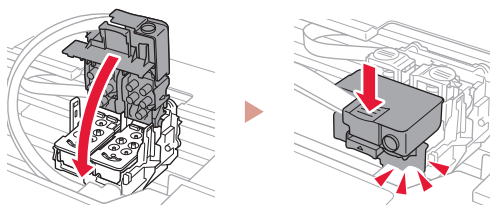

- 6 Zatlačte obe spojovacie tlačidlá úplne dole, kým nezačujete cvaknutie.

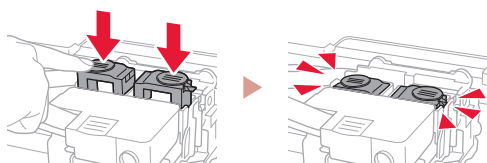

Kontrola!

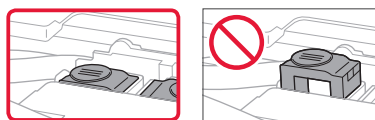

- 7 Zatvorte skenovaciu jednotku/kryt.
- Úplne otvorte skenovaciu jednotku/kryt a následne ju zatvorte.

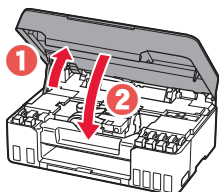

▲ Upozornenie
Dávajte si pozor na prsty.

4. Zapnutie tlačiarne



- 1 Pripojte napájací kábel.

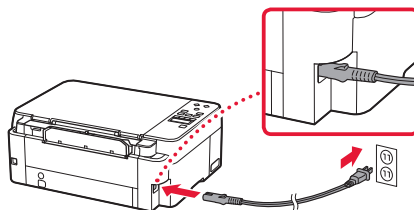

Zadná strana

- 2 Stlačte tlačidlo **ZAP. (ON)**.

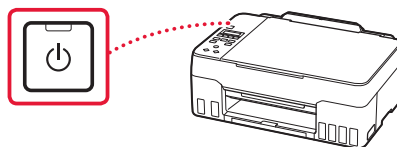

- 3 Keď sa objaví nasledujúca obrazovka, pomocou tlačidiel ◀ a ▶ vyberte jazyk, potom stlačte tlačidlo **OK**.



»»» Dôležité

Ak sa na obrazovke zobrazí chyba, prečítajte si „Ak sa na obrazovke zobrazí chybové hlásenie (kód podpory)“ na strane 5 a postupujte podľa pokynov.

5. Naliatie atramentu



»»» Dôležité

V prípade tohto produktu sa vyžaduje, aby ste s atramentom zaobchádzali opatrne. Z naplnených kaziet s atramentom sa môže vyliat atrament. Ak si atramentom zašpiníte oblečenie alebo iné veci, možno ho nebudete môcť zmyť.

1 Otvorte skenovaciu jednotku/kryt.

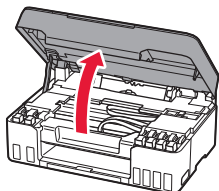

2 Otvorte sivý kryt kazety na ľavej strane tlačiarne.

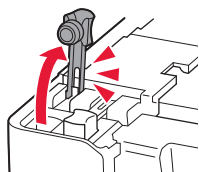

3 Podržte GY (sivú) fľašu s atramentom vo zvislej polohe a jemným otočením odstráňte kryt fľaše.

Kontrola!

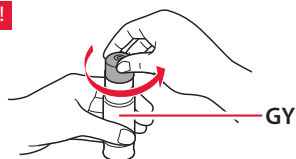

4 Zarovnajte dýzu fľaše s atramentom so vstupom.

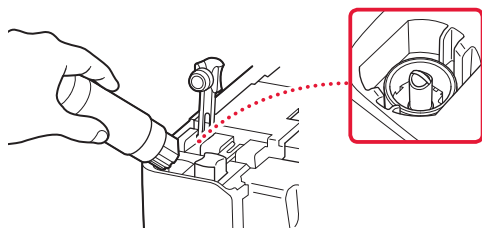

5 Pomaly otočte fľašu s atramentom naopak a stlačením nadol nalejte atrament.

- Ak sa atrament neleje, jemne odstráňte fľašu s atramentom a skúste to znova.

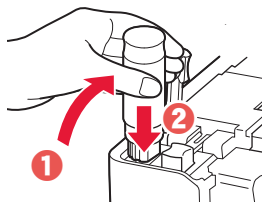

6 Jemne odstráňte fľašu s atramentom zo vstupu.

- Dávajte pozor, aby sa atrament nevyliat.

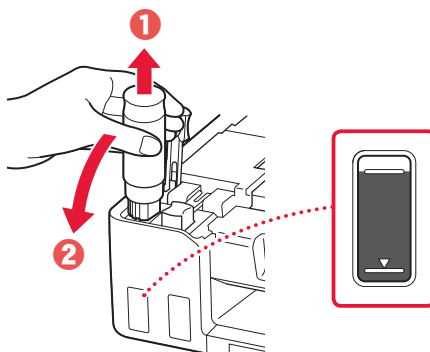

7 Bezpečne nasadte kryt kazety.

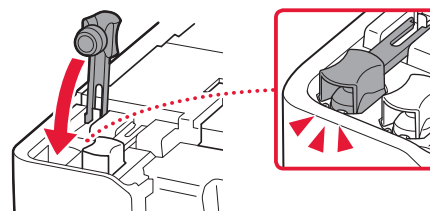

Nastavenie tlačiarne

- 8 Zopakujte kroky 2 až 7 na vyliatie všetkého atramentu všetkých farieb do kaziet s atramentom pre každú farbu.

- Nalejte dodaný atrament, ktorý sa zhoduje s farbou krytu kazety.

Kontrola!

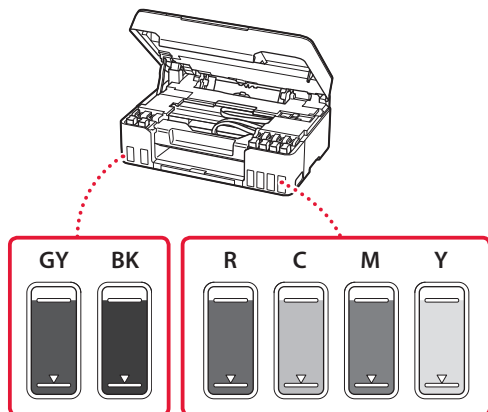

- 9 Zatvorte skenovaciu jednotku/kryt.

- Úplne otvorte skenovaciu jednotku/kryt a následne ju zatvorte.

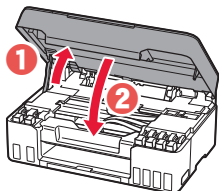

⚠ Upozornenie
Dávajte si pozor na prsty.

- 10 Pomocou tlačidiel ◀ a ▶ vyberte možnosť **Áno (Yes)** a potom stlačte tlačidlo **OK**.

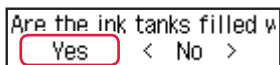

6. Vloženie papiera



- 1 Pomocou tlačidiel ◀ a ▶ vyberte možnosť **Áno (Yes)** a potom stlačte tlačidlo **OK**.



- 2 Vytiahnite podperu papiera.

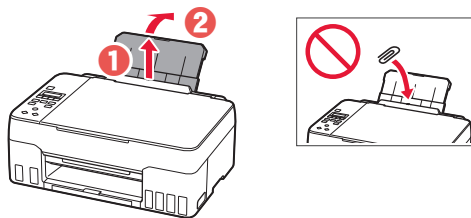

- 3 Otvorte kryt otvoru podávača a posuňte pravú vodiacu lištu papiera úplne vpravo.

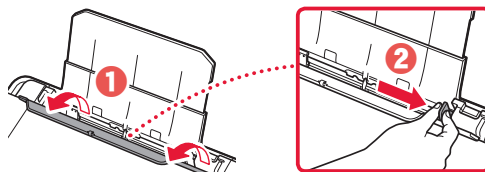

- 4 Vložte papier.

- Vložte 2 alebo viac hárkov obyčajného papiera rozmerov Letter alebo A4.
- Posuňte bočnú vodiacu lištu papiera proti okraju stohu papiera.

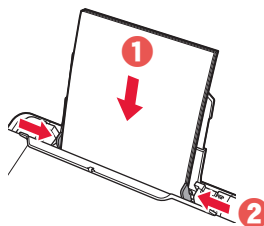

- 5 Zatvorte kryt otvoru podávača.

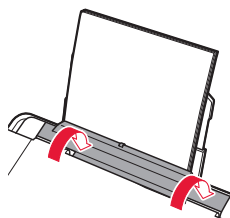

6 Vysuňte výstupný zásobník papiera.

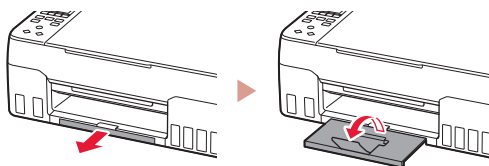

7 Postupujte podľa pokynov na obrazovke a potom stlačte tlačidlo OK.

Load 2 or more sheets of
[OK]Next

Adjusting for first use...
About █ min. remaining

- Chvíľu počkajte, kým sa zobrazí nasledujúca obrazovka.

Do you want to update at
< Yes > No

Setup is complete [OK]

To connect to a computer [OK]

Copy
100% █ 01

Vyberte spôsob pripojenia, ktorý najlepšie zodpovedá vášmu spôsobu používania tlačiarne.

- Používanie tlačiarne bez pripojenia akýchkoľvek iných zariadení
➔ Nastavenie je hotové.
- Používanie tlačiarne pripojením k počítaču alebo smartfónu
➔ Pokračujte na ďalšiu stranu.

? Ak sa na obrazovke zobrazí chybové hlásenie (kód podpory)

Protective material remains
Support code 1890

Kód podpory
(Support code)

Skontrolujte kód podpory a potom postupujte podľa pokynov v prípade, ak je zobrazený kód uvedený nižšie.

- 1890
Ochranný materiál zostal na mieste.
➔ „2. Odstránenie obalového materiálu“ na strane 1
- 1470/1471
Tlačové hlavy nie sú vložené správne.
➔ „3. Vkladanie tlačových hláv“ na strane 1
- 1474
Tlačové hlavy nie sú vložené správne.
Zatvorte páčku atramentového ventilu a vymeňte pravú a ľavú tlačovú hlavu.

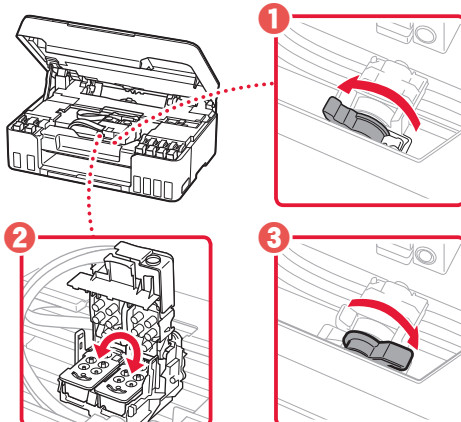

➔ „3. Vkladanie tlačových hláv“ na strane 1

- 5200
Príprava atramentového systému nebola úspešne dokončená.
Stlačením tlačidla **ZAP. (ON)** reštartujte tlačiareň a potom prejdite na kapitolu „5. Naliatie atramentu“ na strane 3.

Informácie o všetkých ostatných prípadoch nájdete v dokumente **Príručka online**.

Aké zariadenie pripájate?



Počítač



Počítač a smartfón





Smartfón

7-a

Pripojenie k počítaču

Ak používate viacero počítačov, zopakujte tieto kroky na každom z nich.



- 1 V počítači prejdite na webovú stránku spoločnosti Canon.
 <https://ij.start.canon>
- 2 Vyberte položku  **Nastavenie**.
- 3 Zadajte názov modelu tlačiarne a kliknite na položku **Prejsť**.
- 4 Kliknite na položku **Štart**.
- 5 Kliknite na položku **(B) Pripojenie k počítaču/smartfónu**.
 - Nasledujúce kroky platia pre používateľov Windows.
- 6 Kliknite na položku **Prevziať**.
- 7 Spustíte prevzatý súbor.
 - Postupujte podľa pokynov na obrazovke. Môže to chvíľu trvať.
 - Ak sa chcete pripojiť aj k smartfónu, pozrite si časť „7-b. Pripojenie k smartfónu“ na strane 7.



Použitie inštalračného disku

Dvakrát kliknite na súbor **EasySetup.exe** na inštalračnom disku a pokračujte od kroku 3. Ak nemáte internetové pripojenie, otvorte priečinok **win** na inštalračnom disku a dvakrát kliknite na súbor **SETUP.exe**. Tým nainštalujete ovládač tlačiarne.

7-b

Pripojenie k smartfónu

Ak používate viacero smartfónov, zopakujte tieto kroky na každom z nich.



1 V smartfóne nainštalujte aplikáciu „Canon PRINT Inkjet/SELPHY“.



- Vyhľadajte „Canon PRINT“ v App Store alebo Google Play.
- Prejdite na webovú stránku spoločnosti Canon a prevezmite si aplikáciu.



2 V smartfóne otvorte nastavenia Wi-Fi. Skontrolujte, že sa zobrazí názov siete (SSID) začínajúci na „Canon_ij_“.

(Príklad iOS obrazovky)

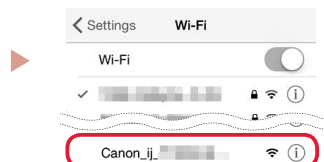

Názov siete (SSID), ktorý začína na „Canon_ij_“

- Ak sa zobrazí „Canon_ij_“, → pokračujte na krok **3**.
- Ak sa „Canon_ij_“ nezobrazí, → pokračujte na krok **4**.

3 Ťuknite na názov siete (SSID), ktorý začína na „Canon_ij_“.

4 Otvorte si nainštalovanú aplikáciu a podľa pokynov na obrazovke v aplikácii pridajte svoju tlačiareň.

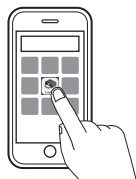

Hneď, ako pridáte svoju tlačiareň, môžete tlačiť zo smartfónu.

Ak chcete tlačiť fotografie, pozrite si časť „Vloženie fotopapiera“ na strane 8.

Vloženie fotopapiera

1 Vytiahnite podporu papiera.

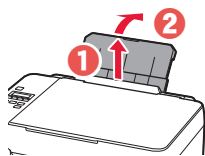

2 Otvorte kryt otvoru podávača a posuňte pravú vodiacu lištu papiera úplne vpravo.

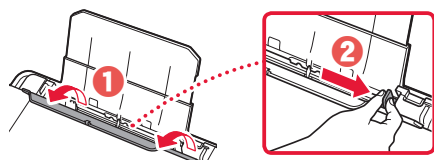

3 Vložte niekoľko hárkov fotografického papiera tak, aby strana, na ktorú sa tlačí, smerovala nahor, a prisuňte bočnú vodiacu lištu papiera k okraju stohu papiera.

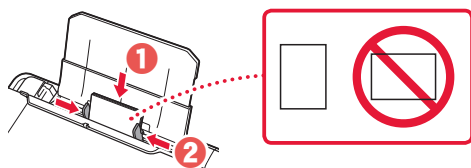

4 Zatvorte kryt otvoru podávača.

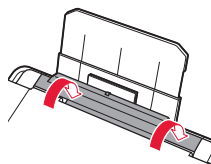

5 Ak sa na obrazovke tlačiarne zobrazila správa s textom **Zaregistrujte informácie o papieri v zadnom zásobníku. (Save the rear tray paper information)**, stlačte tlačidlo **OK**.

6 Vyberte veľkosť a typ papiera a stlačte tlačidlo **OK**.

7 Vysuňte výstupný zásobník papiera.

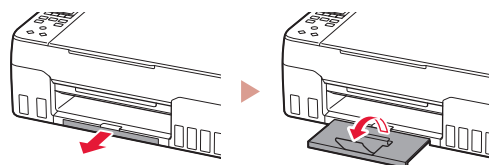

Preprava tlačiarne

Pri premiestňovaní tlačiarne nezabudnite skontrolovať nasledujúce položky. Podrobnosti nájdete v dokumente **Príručka online**.

Skontrolujte, či sú obe spojovacie tlačidlá úplne zatlačené dole, inak by mohol unikáť atrament.

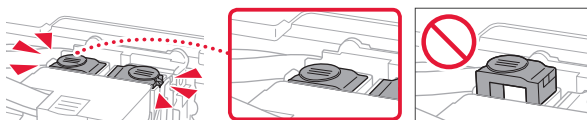

Skontrolujte, že poloha páčky atramentového ventilu je zatvorená.

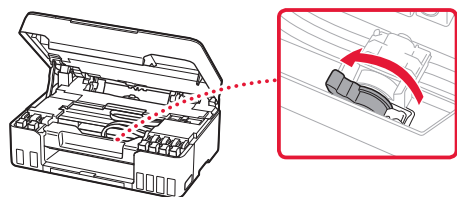

Tlačiareň zabalte do plastovej tašky, keby z nej náhodou unikol atrament.

- Tlačiareň zabalte do pevnej škatule tak, aby spodná strana smerovala nadol. Použite dostatočné množstvo ochranného materiálu, ktoré zaručí bezpečnú prepravu.
- Tlačiareň nenakláňajte. Môže dôjsť k priesaku atramentu.
- Buďte opatrný a dbajte na to, aby škatuľa zostala naplocho a NEBOLA otočená zhora nadol alebo na stranu, keďže tlačiareň sa môže poškodiť a atrament v tlačiarňi môže priesiaknuť.
- Ak prepravu tlačiarne zabezpečuje prepravná spoločnosť, označte škatuľu nápisom „TOUTO STRANOU NAHOR“, aby sa zaručilo, že spodná strana tlačiarne bude smerovať nadol. Škatuľu označte aj nápisom „KREHKÉ“ alebo „POZOR, SKLO“.

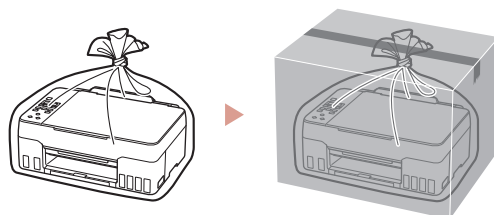

Konfigurowanie drukarki



**Aby wprowadzić ustawienia,
otwórz adres URL**

<https://ij.start.canon>



lub zeskanuj kod z urządzenia mobilnego

• Jeśli nie masz połączenia z Internetem, postępuj zgodnie z poniższymi instrukcjami.

1. Zawartość opakowania

• Głowice drukujące

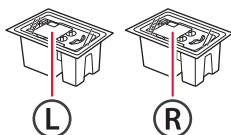

- Butelki z atramentem
- Kabel zasilania
- Instalacyjny dysk CD-ROM
- Informacje o bezpieczeństwie i ważne uwagi
- Pierwsze uruchomienie (ten podręcznik)

2. Usuwanie materiałów opakowaniowych



- 1 Zdejmij i zutylizuj wszelkie materiały opakowaniowe oraz pomarańczową taśmę.
- 2 Otwórz moduł skanera/pokrywę, zdejmij i zutylizuj pomarańczową taśmę oraz materiał ochronny wewnątrz.

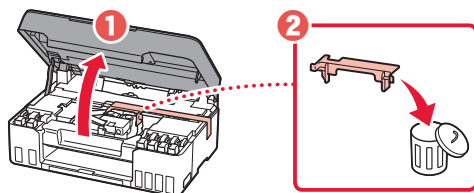

3. Wkładanie głowic drukujących



- 1 Otwórz pokrywę blokującą głowicy drukującej.

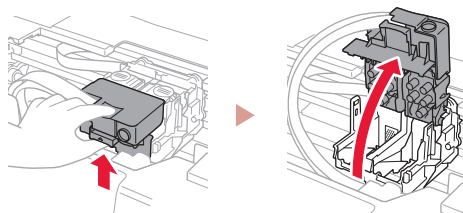

- 2 Wyjmij każdą głowicę drukującą z opakowania i zdejmij etykietę.

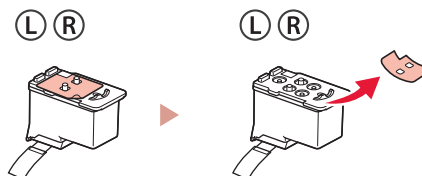

- 3 Usuń pomarańczową taśmę.

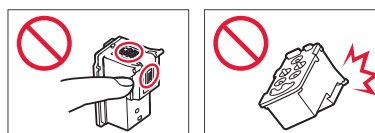
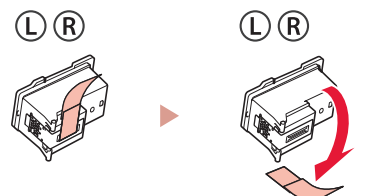

Konfigurowanie drukarki

- 4 Włóż głowicę drukującą L po lewej stronie, a głowicę drukującą R po prawej.

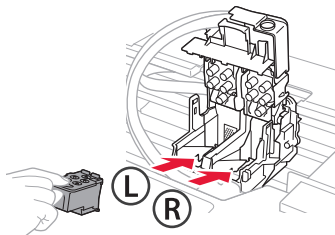

- 5 Zamknij pokrywę blokującą głowicy drukującej i dociśnij ją do kliknięcia.

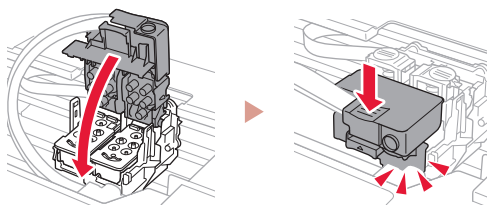

- 6 Wciśnij do końca oba przyciski połączenia, aż usłyszysz kliknięcie.

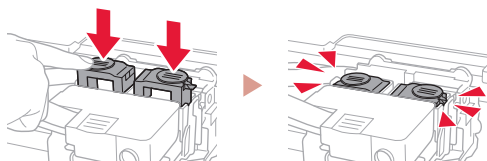

Sprawdź!

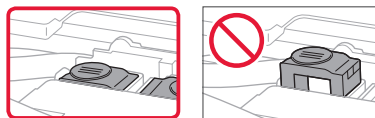

- 7 Zamknij moduł skanera/pokrywę.
- Otwórz do końca moduł skanera/pokrywę, a następnie zamknij je.

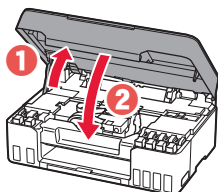

⚠ Przewaga
Uważaj na palce.

4. Włączanie drukarki



- 1 Podłącz kabel zasilania.

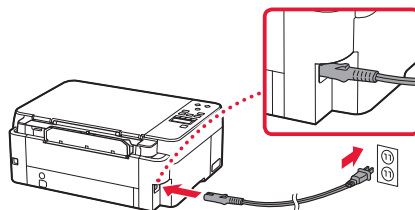

Z tyłu

- 2 Naciśnij przycisk **WŁ. (ON)**.

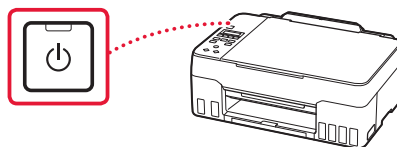

- 3 Po wyświetleniu pokazanego ekranu naciśnij przyciski ◀ i ▶, aby wybrać język, a następnie naciśnij przycisk **OK**.



Ważne

Jeśli na ekranie pojawi się błąd, patrz „Jeśli na ekranie pojawi się błąd (kod pomocniczy)” na stronie 5 i postępuj zgodnie z instrukcjami.

5. Nalewanie atramentu



Ważne

Ten produkt wymaga ostrożności przy pracy z atramentem. Gdy zbiorniki z atramentem są pełne, może dojść do rozprysków. Atrament ciężko schodzi z ubrań i przedmiotów.

1 Otwórz moduł skanera/pokrywę.

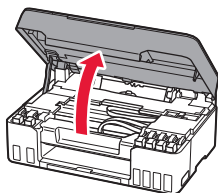

2 Otwórz szarą nasadkę zbiornika po lewej stronie drukarki.

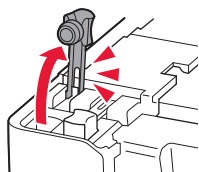

3 Trzymając (szarą) butelkę z atramentem GY pionowo, delikatnie odkręć i zdejmij zakrętkę butelki.

Sprawdź!

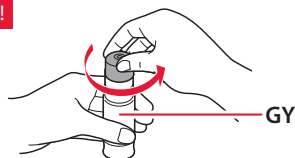

4 Dopasuj dyszę butelki z atramentem do wlotu.

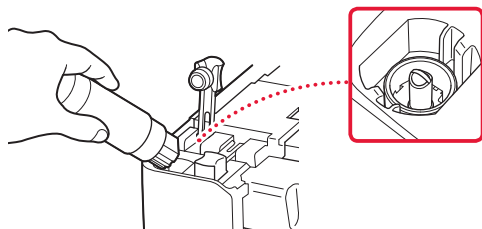

5 Powoli postaw butelkę z atramentem do góry nogami i dociśnij ją, aby wlać atrament.

- Jeśli tusz się nie wylewa, zdejmij delikatnie butelkę z atramentem i spróbuj ponownie.

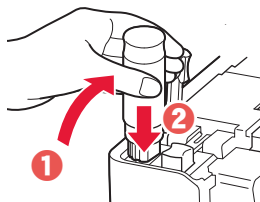

6 Delikatnie wyjmij butelkę z atramentem z wlotu.

- Uważaj, aby nie rozlać atramentu.

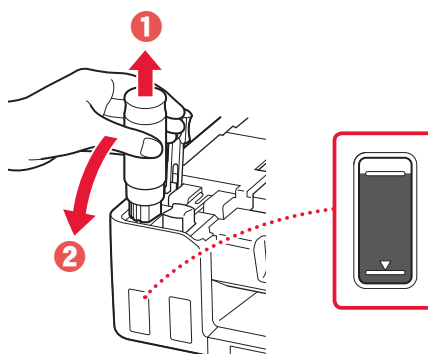

7 Dokładnie załóż z powrotem nasadkę zbiornika.

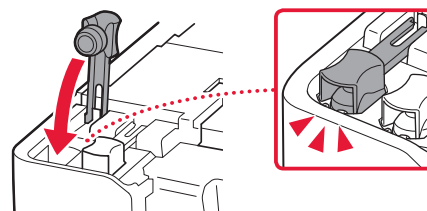

Konfigurowanie drukarki

8 Powtórz kroki od 2 do 7, aby włąć atramenty do zbiorników z atramentem dla poszczególnych kolorów.

- Wlej dostarczony atrament, którego kolor odpowiada kolorowi nasadki zbiornika.

Sprawdź!

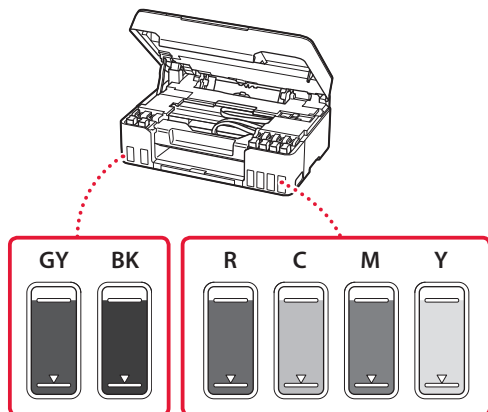

9 Zamknij moduł skanera/pokrywę.

- Otwórz do końca moduł skanera/pokrywę, a następnie zamknij je.

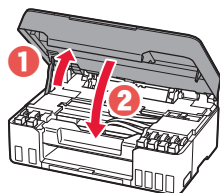

⚠ Przewaga
Uważaj na palce.

10 Za pomocą przycisków ◀ i ▶ wybierz opcję **Tak (Yes)**, a następnie naciśnij przycisk **OK**.

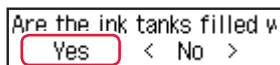

6. Ładowanie papieru



1 Za pomocą przycisków ◀ i ▶ wybierz opcję **Tak (Yes)**, a następnie naciśnij przycisk **OK**.

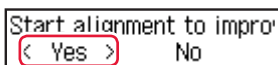

2 Wysuń podpórkę papieru.

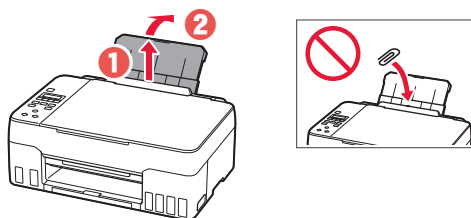

3 Otwórz pokrywę otworu podajnika i przesun prawą prowadnicę papieru maksymalnie w prawo.

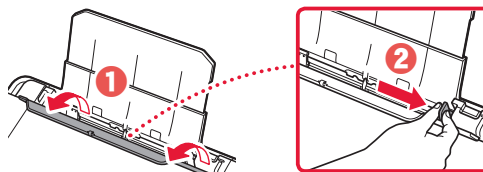

4 Załaduj papier.

- Załaduj 2 lub więcej arkuszy zwykłego papieru w formacie Letter lub A4.
- Dosuń bok prowadnicy papieru do krawędzi stosu papieru.

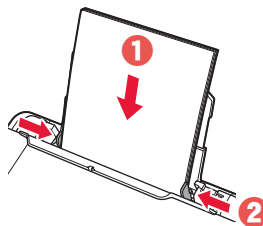

5 Zamknij pokrywę otworu podajnika.

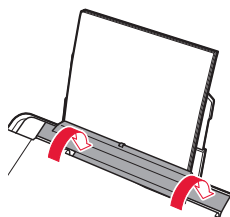

6 Wsuń tacę wyprowadzania papieru.

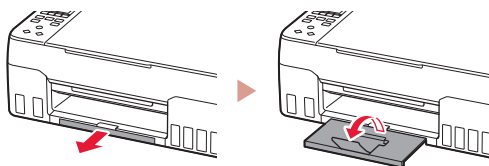

7 Postępuj zgodnie z instrukcjami wyświetlanymi na ekranie, a następnie naciśnij przycisk **OK**.

Load 2 or more sheets of
[OK]Next

Adjusting for first use...
About █ min. remaining

- Poczekaj chwilę do wyświetlenia poniższego ekranu.

Do you want to update at
< Yes > No

Setup is complete
[OK]

To connect to a computer
[OK]

Copy
100% █ 01

Wybierz sposób podłączenia optymalnie pasujący do sposobu używania drukarki.

- Używanie drukarki bez podłączania do niej żadnych urządzeń
➔ Konfiguracja jest ukończona.
- Używanie drukarki z komputerem lub smartfonem
➔ Przejdź do następnej strony.

? Jeśli na ekranie pojawi się błąd (kod pomocniczy)

Protective material rema
Support code 1890

Kod pomocn.
(Support code)

Sprawdź kod pomocniczy i postępuj zgodnie z instrukcjami, jeśli wyświetlony kod jest napisany poniżej.

- 1890
Pozostał materiał ochronny.
➔ „2. Usuwanie materiałów opakowaniowych” na stronie 1
- 1470/1471
Główce drukujące nie są poprawnie zainstalowane.
➔ „3. Wkładanie głowic drukujących” na stronie 1
- 1474
Główce drukujące nie są poprawnie zainstalowane.
Zamknij dźwignię zaworu atramentu i zamień miejscami główce drukujące lewą i prawą.

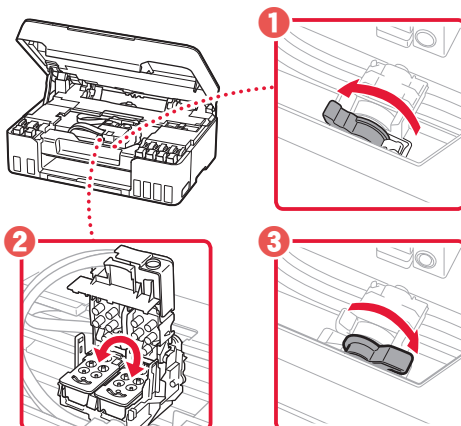

➔ „3. Wkładanie głowic drukujących” na stronie 1

- 5200
Przygotowanie systemu atramentu nie powiodło się.
Naciśnij przycisk **WŁ. (ON)**, aby ponownie uruchomić drukarkę, a następnie patrz „5. Nalewanie atramentu” na stronie 3.

W pozostałych przypadkach wybierz opcję **Podręcznik online**.

Które urządzenie podłączasz?



Komputer



Komputer i
smartfon





Smartfon

7-a

Łączenie z komputerem

Jeśli korzystasz z wielu komputerów, wykonaj te kroki na każdym z nich.



- 1 Na komputerze przejdź do witryny firmy Canon w sieci Web.
 <https://ij.start.canon>
- 2 Wybierz opcję  **Konfiguracja**.
- 3 Wprowadź nazwę modelu drukarki i kliknij opcję **Przejdź**.
- 4 Kliknij opcję **Uruchom**.
- 5 Kliknij opcję **(B) Łączenie z komputerem/ smartfonem**.
 - Następujące kroki przeznaczone są dla urządzeń z systemem Windows.
- 6 Kliknij opcję **Pobierz**.
- 7 Uruchom pobrany plik.
 - Postępuj zgodnie z instrukcjami wyświetlanymi na ekranie. Może to zająć trochę czasu.
 - Aby połączyć także ze smartfonem, zobacz „7-b. Łączenie ze smartfonem” na stronie 7.



Używanie instalacyjnego dysku CD-ROM

Kliknij dwukrotnie plik **EasySetup.exe** na dysku CD-ROM, a następnie kontynuuj od kroku 3. Jeśli nie ma połączenia z Internetem, otwórz folder **win** na dysku CD-ROM i dwukrotnie kliknij plik **SETUP.exe**. Rozpocznie się instalacja sterownika drukarki.

7-b

Łączenie ze smartfonem

Jeśli korzystasz z wielu smartfonów, wykonaj te kroki na każdym z nich.



1 Zainstaluj aplikację „Canon PRINT Inkjet/SELPHY” w smartfonie.



- Wyszukaj aplikację „Canon PRINT” w sklepie App Store lub Google Play.
- Aby pobrać aplikację, otwórz stronę internetową firmy Canon.



2 Otwórz ustawienia Wi-Fi na smartfonie. Sprawdź, czy jest widoczna nazwa sieci (SSID) zaczynająca się od ciągu „Canon_ij_”.

(Przykład ekranu iOS)

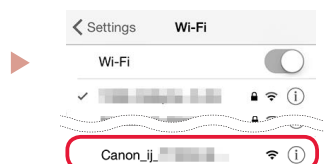

Nazwa sieci (SSID) zaczynająca się od ciągu „Canon_ij_”

- Jeśli pojawi się komunikat „Canon_ij_”, → przejdź do kroku **3**.
- Jeśli nie pojawi się komunikat „Canon_ij_”, → przejdź do kroku **4**.

3 Dotknij nazwę sieci (SSID) zaczynającą się od ciągu „Canon_ij_”.

4 Otwórz zainstalowaną aplikację i postępuj zgodnie z instrukcjami wyświetlanymi na ekranie aplikacji, aby dodać drukarkę.



Po dodaniu drukarki możesz drukować za pomocą smartfona.

Aby drukować zdjęcia, zobacz „Ładowanie papieru fotograficznego” na stronie 8.

Ładowanie papieru fotograficznego

1 Wsuń podpórkę papieru.

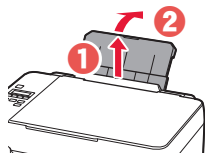

2 Otwórz pokrywę otworu podajnika i przesun prawą prowadnicę papieru maksymalnie w prawo.

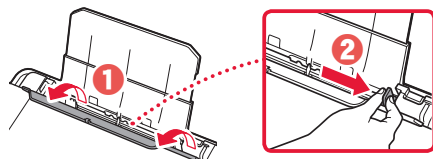

3 Załaduj kilka arkuszy papieru fotograficznego stroną do zadrukowania skierowaną do góry i dosuń bok prowadnicy papieru do krawędzi stosu papieru.

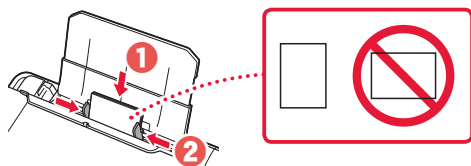

4 Zamknij pokrywę otworu podajnika.

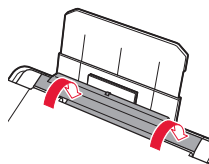

5 Gdy na ekranie pojawi się komunikat **Rejestruj dane o papierze w tylnej tacy (Save the rear tray paper information)**, naciśnij przycisk **OK**.

6 Wybierz rozmiar i typ papieru oraz naciśnij przycisk **OK**.

7 Wsuń tacę wyprowadzania papieru.

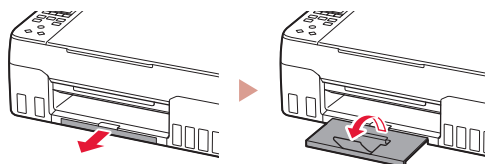

Transportowanie drukarki

Przy zmianie ustawienia drukarki sprawdź następujące elementy. Szczegółowe informacje na ten temat podano w dokumencie **Podręcznik online**.

Upewnij się, że oba przyciski połączenia są wciśnięte do końca, aby uniknąć wycieku atramentu.

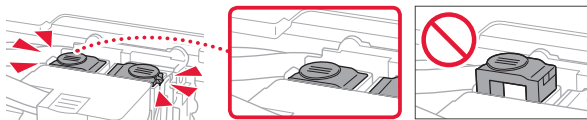

Sprawdź, czy dźwignia zaworu atramentu jest w pozycji zamkniętej.

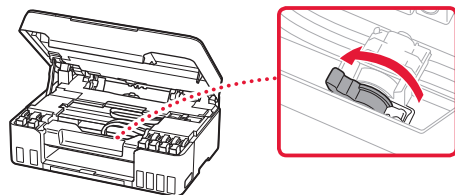

Włóż drukarkę do plastikowej torby na wypadek wycieku atramentu.

- Zapakuj drukarkę do solidnego pudełka spodem do dołu, używając wystarczającej ilości materiału ochronnego, która zapewni bezpieczny transport.
- Nie przechylaj drukarki. Może dojść do wycieku atramentu.
- Obchodź się z pudełkiem ostrożnie i upewnij się, że pudełko będzie leżeć płasko oraz NIE zostanie ustawione do góry nogami ani na boku, ponieważ mogłoby to spowodować uszkodzenie drukarki i wyciek atramentu.
- Jeśli transportem drukarki zajmuje się firma spedycyjna, należy poprosić o oznaczenie pudła napisem „TA STRONA DO GÓRY”, aby drukarka znajdowała się cały czas w pozycji spodem do dołu. Oznacz pudełko także oznaczeniami „OSTROŻNIE!”.

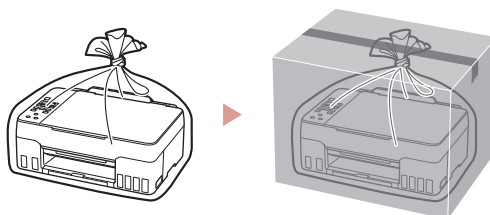

A nyomtató beüzemelése



A beüzemeléshez látogasson el a következő URL-címre:

<https://ij.start.canon>



vagy mobileszközével olvassa be a kódot

•Ha nem rendelkezik internetkapcsolattal, kövesse az alábbi utasításokat!

1. A doboz tartalma

• Nyomtatófejek

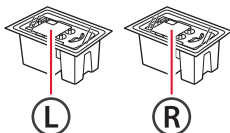

- Tintaflakonok
- Tápkábel
- Telepítő CD-ROM
- Biztonsági és fontos tudnivalók
- Beüzemelési útmutató (ez a kézikönyv)

2. A csomagolóanyag eltávolítása



- 1 Távolítsa el és dobja ki minden csomagolóanyagot és narancssárga szalagot.
- 2 Nyissa fel a lapolvasó egységet/fedelet, és vegye ki az eszköz belsejéből és dobja ki a narancssárga szalagot és a védőanyagot.

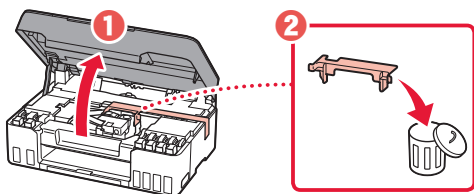

3. A nyomtatófejek behelyezése



- 1 Nyissa fel a nyomtatófej zárófedelét.

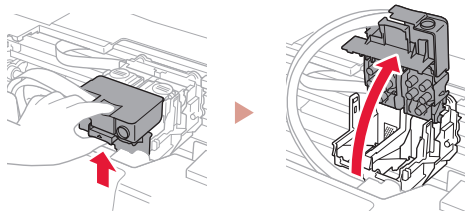

- 2 Vegye ki mindegyik nyomtatófejet a csomagból, és távolítsa el a címkéjét.

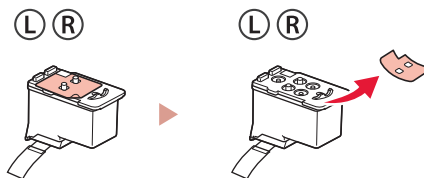

- 3 Távolítsa el a narancssárga szalagot.

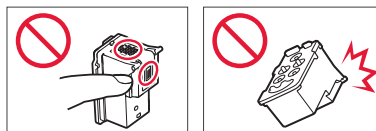
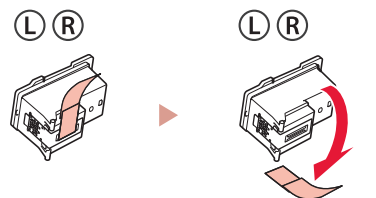

A nyomtató beüzemelése

- 4 Tegye be az L nyomtatófejet a bal oldalra, az R nyomtatófejet pedig a jobb oldalra.

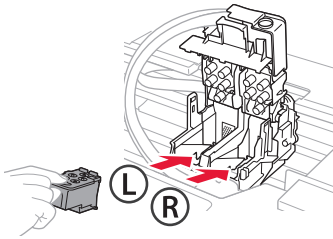

- 5 Cszkja le a nyomtatófej zárófedelét, és kattanásig nyomja le.

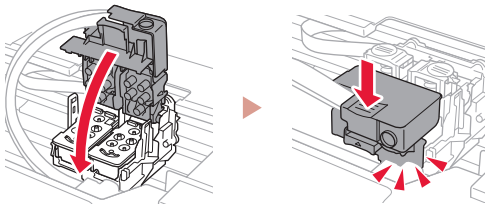

- 6 Nyomja le teljesen, kattanásig mindkét összekötő gombot.

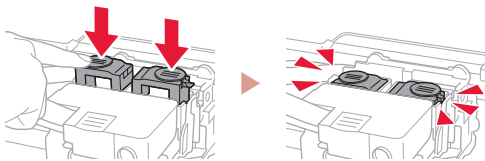

Ellenőrizze!

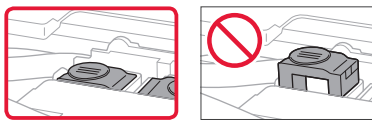

- 7 Cszkja le a lapolvasó egységet/fedelet.
- Teljesen nyissa fel a lapolvasó egységet/fedelet, majd csukja le.

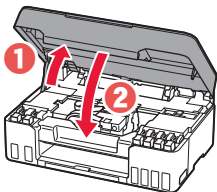

▲ **Figyelem**
Ügyeljen az ujjára!

4. A nyomtató bekapcsolása



- 1 Csatlakoztassa a tápkábelt.

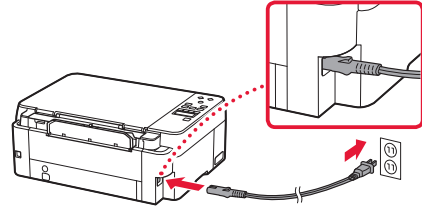

Hátoldal

- 2 Nyomja meg a **BE (ON)** gombot.

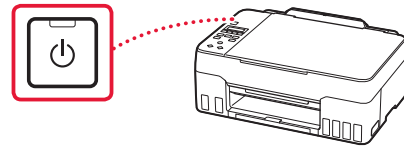

- 3 Amikor megjelenik a következő képernyő, a ◀ és a ▶ gombbal válasszon ki egy nyelvet, és nyomja meg az **OK** gombot.



▶▶▶ **Fontos**

Ha hiba jelenik meg a képernyőn, akkor nézze meg a „Ha hibaüzenetet (támogatási kód) jelenik meg a képernyőn”, 5. oldal szakaszt, és kövesse az utasításokat.

5. A tinta betöltése



Fontos

E termék esetén óvatosan kell bánni a tintával. Amikor a tintatartályok tele vannak tintával, a tinta kifolyhat. Ha a tinta a ruhájára vagy egyéb holmijára kerül, előfordulhat, hogy a folt nem távolítható el.

1 Nyissa fel a lapolvasó egységet/fedelet.

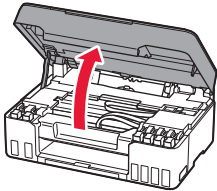

2 A nyomtató bal oldalán nyissa ki a szürke tartálysapkát.

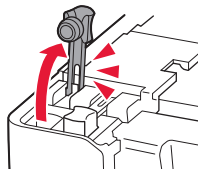

3 Tartsa függőlegesen a GY (szürke) tintaflakont, és óvatosan csavarja le a flakon sapkáját.

Ellenőrizze!

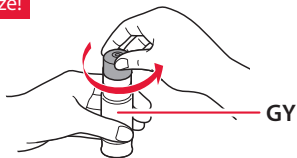

4 Illesse a tintaflakon kiöntőcsövét a bemenetbe.

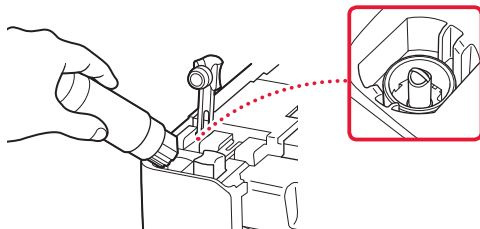

5 Lassan fordítsa fel a tintaflakont, és nyomja le, hogy befolyhasson a tinta.

- Ha nem folyik a tinta, akkor óvatosan vegye el a tintaflakont, és próbálja meg újra.

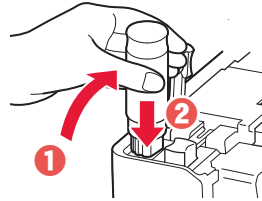

6 Óvatosan vegye el a tintaflakont a bemenettől.

- Vigyázzon, nehogy kimenjen a tinta!

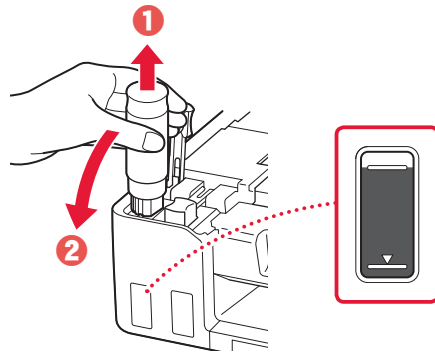

7 Tegye vissza megfelelően a tartálysapkát.

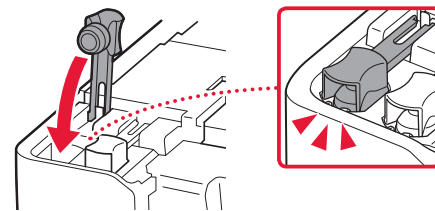

A nyomtató beüzemelése

8 A 2–7. lépéseket megismételve öntse bele a tintát minden színhez az egyes színekhez tartozó tintatartályokba.

- A tartálysapka színének megfelelő mellékelt tintát öntse be.

Ellenőrizze!

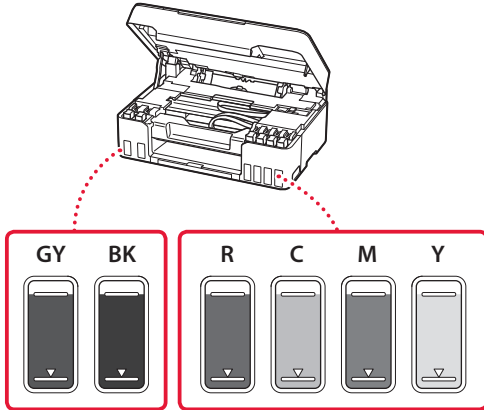

9 Cszukja le a lapolvasó egységet/fedelet.

- Teljesen nyissa fel a lapolvasó egységet/fedelet, majd csukja le.

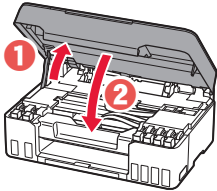

Figyelem
Ügyeljen az ujjára!

10 A ◀ és a ▶ gombbal jelölje ki az **Igen (Yes)** elemet, majd nyomja meg az **OK** gombot.

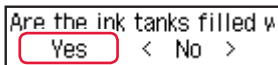

6. Papír betöltése



1 A ◀ és a ▶ gombbal jelölje ki az **Igen (Yes)** elemet, majd nyomja meg az **OK** gombot.



2 Húzza ki a papírtámaszt.

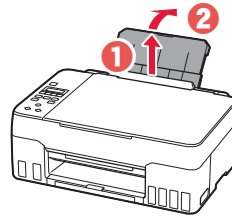

3 Nyissa fel az adagolónyiás fedelét, és tolja a jobb oldali papírvetítőt a jobb szélre.

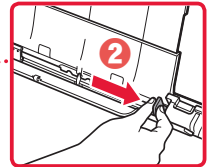
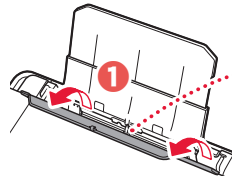

4 Töltsön be papírt.

- Tegyen be legalább 2 Letter vagy A4 méretű normál papírlapot.
- Tolja az oldalsó papírvetítőt a papírköteg oldalához.

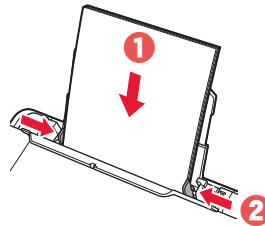

5 Cszukja le az adagolónyiás fedelét.

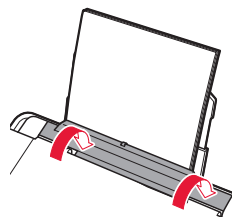

6 Húzza ki a papírgyűjtő tálcát.

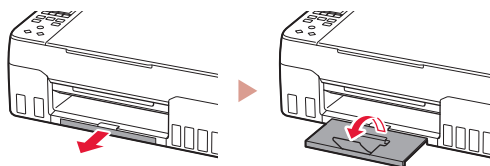

7 Kövesse a képernyőn megjelenő utasításokat, majd nyomja meg az **OK** gombot.

Load 2 or more sheets of
[OK]Next

Adjusting for first use...
About 1 min. remaining

- Várjon egy kicsit, amíg meg nem jelenik a következő képernyő.

Do you want to update at
< Yes > No

Setup is complete [OK]

To connect to a computer [OK]

Copy
100% 01

Válassza ki azt a csatlakoztatási módszert, amely a leginkább megfelel annak, ahogyan a nyomtatót használni fogja.

- Ha a nyomtatót más eszközhöz történő csatlakoztatás nélkül szeretné használni
➔ Befejeződött az üzembe helyezés.
- Ha a nyomtatót számítógéphez vagy okostelefonhoz csatlakoztatva szeretné használni
➔ Folytassa a következő oldalon.

? Ha hibaüzenetet (támogatási kód) jelenik meg a képernyőn

Protective material rema
Support code 1890

Támogat. kód
(Support code)

Nézze meg a támogatási kódot, majd kövesse a megjelölt kódhoz tartozóan alább megadott utasításokat, ha a kód szerepel az alábbi listán.

- 1890
Nem lett eltávolítva minden védőanyag.
➔ „2. A csomagolóanyag eltávolítása”, 1. oldal
- 1470/1471
Nincsenek megfelelően betéve a nyomtatófejek.
➔ „3. A nyomtatófejek behelyezése”, 1. oldal
- 1474
Nincsenek megfelelően betéve a nyomtatófejek.
Zárja le a tintaszep karját, és cserélje meg a bal és a jobb oldali nyomtatófejeket.

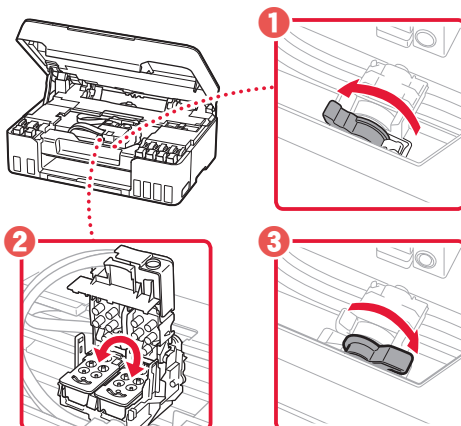

➔ „3. A nyomtatófejek behelyezése”, 1. oldal

- 5200
Nem fejeződött be sikeresen a tintarendszer előkészítése. A **BE (ON)** gomb megnyomásával indítsa újra a nyomtatót, majd olvassa el a következő szakaszt: „5. A tinta betöltése”, 3. oldal.

Minden egyéb esetben kövesse az **Online kézikönyv** útmutatásait.

Milyen eszközt csatlakoztat?



Számítógép



Számítógép és
okostelefon



Okostelefon

7-a

Csatlakoztatás számítógéphez

Ha több számítógépet használ, akkor a következő lépéseket mindegyik számítógépen hajtsa végre.



- 1 A számítógépen látogasson el a Canon webhelyére.
 <https://ij.start.canon>
- 2 Válassza a  **Beüzemelés** elemet.
- 3 Írja be a nyomtató modellnevét, és kattintson az **Ugrás** gombra.
- 4 Kattintson az **Indítás** gombra.
- 5 Kattintson a **(B) Csatlakoztatás számítógéphez/okostelefonhoz** elemre.
 - A következő lépéseket Windows operációs rendszer esetében kell végrehajtani.
- 6 Kattintson a **Letöltés** gombra.
- 7 Futtassa a letöltött fájlt.
 - Kövesse a képernyőn megjelenő utasításokat. Ez eltarthat egy ideig.
 - Ha okostelefonhoz is szeretné csatlakoztatni, akkor olvassa el a következő fejezetet: „7-b. Csatlakoztatás okostelefonhoz”, 7. oldal.



A telepítő CD-ROM használata

Kattintson duplán a CD-ROM **EasySetup.exe** fájljára, majd folytassa a 3. lépéstől. Ha nem rendelkezik internetkapcsolattal, akkor nyissa meg a CD-ROM **win** mappáját, és kattintson a **SETUP.exe** fájlra. Ez telepíteni fogja a nyomtatóillesztőt.

7-b

Csatlakoztatás okostelefonhoz

Ha több okostelefont használ, akkor a következő lépéseket mindegyik okostelefonon hajtsa végre.



1 Telepítse az okostelefonjára a „Canon PRINT Inkjet/SELPHY” alkalmazást.



- Keresse meg a „Canon PRINT” alkalmazást az App Store vagy a Google Play áruházban.
- Az alkalmazás letöltéséhez látogasson el a Canon webhelyére.



2 Nyissa meg az okostelefon Wi-Fi-beállításait. Ellenőrizze, látható-e a „Canon_ij_” karaktersorozattal kezdődő hálózati név (SSID).

(A példa az iOS képernyőjét mutatja)

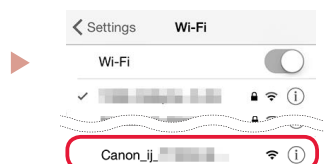

A „Canon_ij_” karaktersorozattal kezdődő hálózati név (SSID)

- Ha látható „Canon_ij_” → folytassa a **3.** lépéssel.
- Ha nem látható „Canon_ij_” → folytassa a **4.** lépéssel.

3 Koppintson a „Canon_ij_” karaktersorozattal kezdődő hálózati névre (SSID-re).

4 Nyissa meg a telepített alkalmazást, majd az alkalmazás képernyőin megjelenő utasításokat követve adja hozzá a nyomtatót.

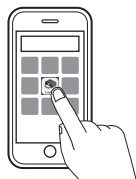

Miután hozzáadta a nyomtatót, nyomtathat az okostelefonról.

Ha fényképeket szeretne nyomtatni, olvassa el a következő fejezetet: „Fotópapír betöltése”, 8. oldal.

Fotópapír betöltése

1 Húzza ki a papírtámaszt.

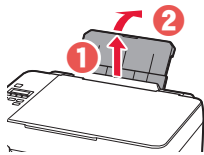

2 Nyissa fel az adagolónyílás fedelét, és tolja a jobb oldali papírvezetőt a jobb szélre.

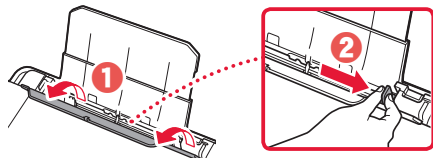

3 Tegyen be néhány fotópapírlapot úgy, hogy nyomtatási oldala felfelé nézzen, és tolja a papírvezetőt a papírköteg oldalához.

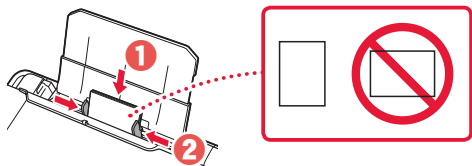

4 Cukja le az adagolónyílás fedelét.

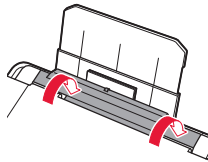

5 Amikor a nyomtató képernyőjén megjelenik a **Hátsó tálca papíradatainak regisztrálása (Save the rear tray paper information)** üzenet, nyomja meg az **OK** gombot.

6 Válassza ki a papír méretét és típusát, majd nyomja meg az **OK** gombot.

7 Húzza ki a papírgyűjtő tálcat.

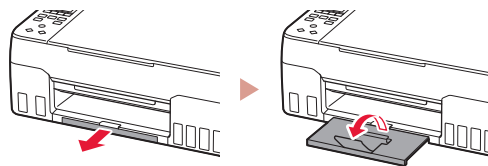

A nyomtató szállítása

Amikor szállítja a nyomtatót, ellenőrizze a következőket. A részleteket az **Online kézikönyv** tartalmazza.

A tintaszivárgás elkerülése érdekében ellenőrizze, hogy mindkét összekötő gomb teljesen le van-e nyomva.

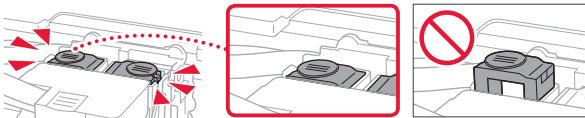

Ellenőrizze, hogy a tintaszelep karja zárt helyzetben áll-e.

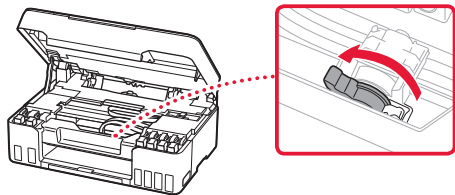

Ha szivárog a tinta, a nyomtatót tegye műanyagzsákba.

- Csomagolja a nyomtatót egy erős dobozba úgy, hogy a nyomtató alsó fele nézzen lefelé; gondoskodjon a biztonságos szállításhoz szükséges elegendő védőanyagról.
- Ne döntse meg a nyomtatót, mert kifolyhat a tinta!
- Óvatosan bánjon vele, és ügyeljen arra, hogy a doboz vízszintes maradjon és NE forduljon fel vagy az oldalára, mert tönkremehet a nyomtató és kifolyhat a tinta a nyomtatóban.
- Ha egy szállítócég végzi a nyomtató szállítását, jelölje meg a nyomtató dobozát „EZ A FELSŐ OLDAL” felirattal, hogy mindig a nyomtató alsó fele nézzen lefelé. Helyezze el a „TÖRÉKENY” vagy az „ÓVATOSAN KEZELENDŐ” feliratot is.

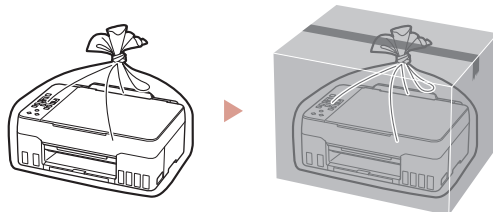

Yazıcıyı Ayarlama



Kurulum için URL'yi ziyaret edin:
<https://ij.start.canon>



ya da mobil aygıtınızla kodu tarayın

• İnternet bağlantınız yoksa, aşağıdaki yönergeleri izleyin.

1. Kutu İçeriği

• Yazıcı Kafaları

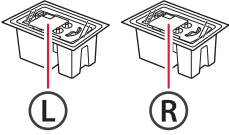

- Mürekkep Şişeleri
- Güç Kablosu
- Kurulum CD-ROM'u
- Güvenlik ve Önemli Bilgiler
- Başlangıç Kılavuzu (bu el kitabı)

2. Koruyucu Malzemeleri Çıkarma



- 1 Koruyucu malzemeleri ve turuncu bandı çıkarıp atın.
- 2 Tarama birimini / kapağı açın, içindeki turuncu bandı ve koruyucu malzemeyi çıkarıp atın.

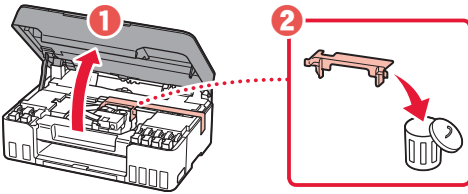

3. Yazıcı Kafalarını Takma



- 1 Yazıcı kafası kilitleme kapağını açın.

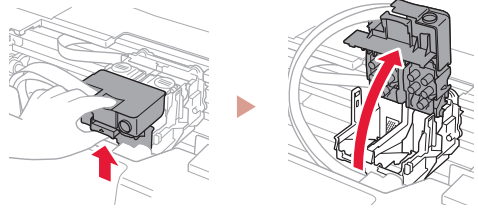

- 2 Her bir yazıcı kafasını paketten çıkarın ve etiketi kaldırın.

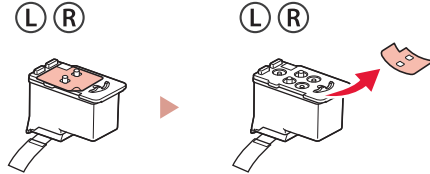

- 3 Turuncu bandı çıkarın.

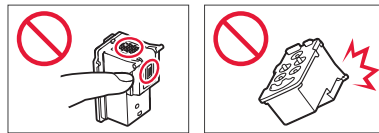
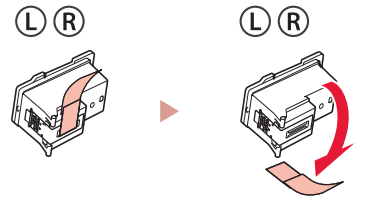

Yazıcıyı Ayarlama

- 4 Soldaki L yazıcı kafasını ve sağdaki R yazıcı kafasını takın.

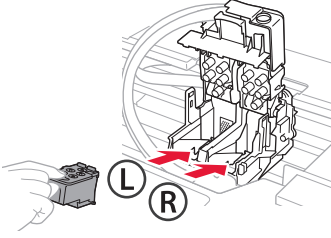

- 5 Yazıcı kafasını kilitleme kapağını kapatın ve tık sesiyle yerine oturana kadar aşağı doğru bastırın.

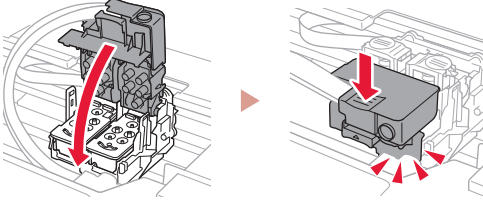

- 6 Ek düğmelerinin her ikisi de tık sesiyle tamamen yerine oturana kadar aşağı doğru bastırın.

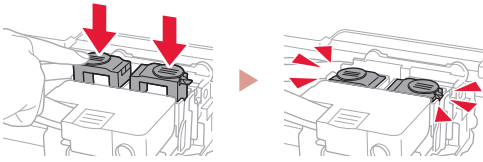

Kontrol edin!

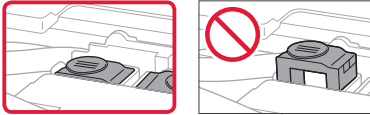

- 7 Tarama birimini / kapağı kapatın.

- Tarama birimini / kapağını tamamen açın ve ardından kapatın.

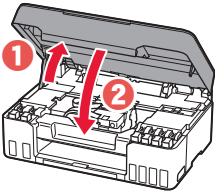

⚠ Dikkat

Parmaklarınıza dikkat edin.

4. Yazıcıyı Açma



- 1 Güç kablosunu takın.

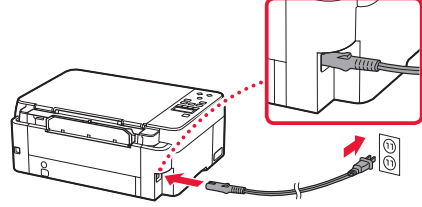

Arka

- 2 **Açma (ON)** düğmesine basın.

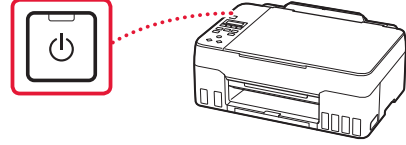

- 3 Aşağıdaki ekran görüntülediğinde, ◀ ve ▶ düğmelerini kullanarak dili seçin ve ardından **OK** düğmesine basın.



»»» Önemli

Ekrana bir hata çıkarsa, "Ekranda bir hata mesajı (destek kodu) belirlirse", sayfa 5 bölümüne bakın ve yönergeleri izleyin.

5. Mürekkebi Dökme



Önemli

Bu ürün, mürekkebin dikkatli bir şekilde kullanılmasını gerektirir. Mürekkep kutuları mürekkeple doldurulduğunda mürekkep sıçrayabilir. Mürekkep elbiselerinize veya eşyalarınıza bulaşırsa çıkmayabilir.

1 Tarama birimini / kapağını açın.

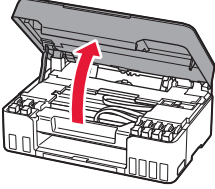

2 Yazıcının solundaki gri kutu kapağını açın.

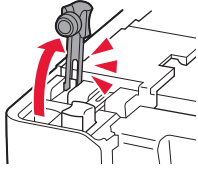

3 GY (gri) mürekkep şişesini dik tutun ve şişe kapağını yavaşça çevirerek çıkarın.

Kontrol edin!

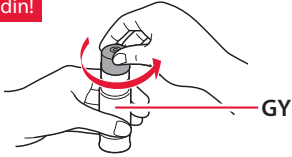

4 Mürekkep şişesinin püskürtme ucunu giriş ile hizalayın.

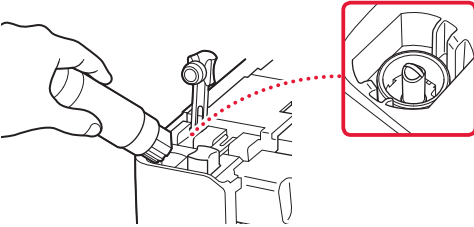

5 Mürekkep şişesini yavaşça baş aşağı çevirin ve mürekkebi dökmek için bastırın.

- Mürekkep dökülmezse, mürekkep şişesini yavaşça çıkarın ve tekrar deneyin.

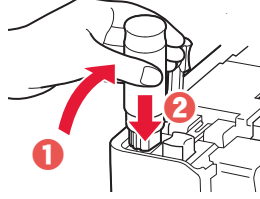

6 Mürekkep şişesini girişten yavaşça çıkarın.

- Mürekkebi dökmemeye özen gösterin.

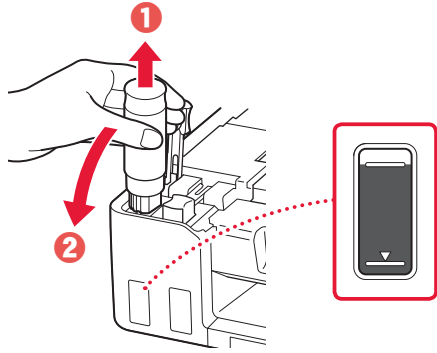

7 Kutu kapağını **emniyetli bir şekilde** yerine geri takın.

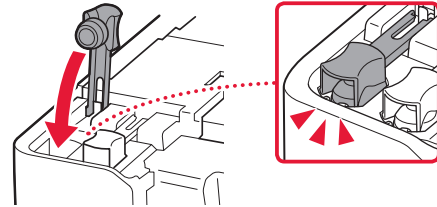

Yazıcıyı Ayarlama

- 8 2 – 7 arası adımları tekrarlayarak tüm mürekkebi, her renk kendi mürekkep kutusunda olacak şekilde dökün.

- Kutu kapağındaki renkle eşleşen verilen mürekkebi dökün.

Kontrol edin!

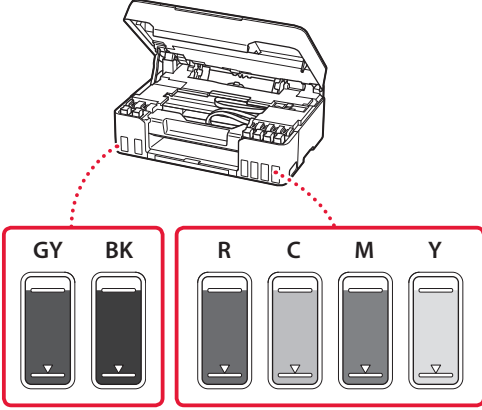

- 9 Tarama birimini / kapağı kapatın.

- Tarama birimini / kapağını tamamen açın ve ardından kapatın.

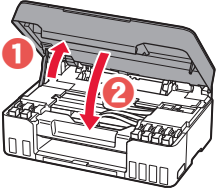

⚠ Dikkat
Parmaklarınıza dikkat edin.

- 10 ◀ ve ▶ düğmelerini kullanarak **Evet (Yes)** ögesini seçin ve ardından **OK** düğmesine basın.

Are the ink tanks filled w
 Yes < No >

6. Kağıt Yerleştirme



- 1 ◀ ve ▶ düğmelerini kullanarak **Evet (Yes)** ögesini seçin ve ardından **OK** düğmesine basın.

Start alignment to impro
 Yes < No >

- 2 Kağıt desteğini uzatın.

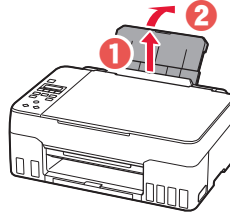

- 3 Besleme yuvası kapağını açın ve sağ kağıt kılavuzunu en sağa kaydırın.

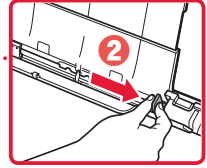
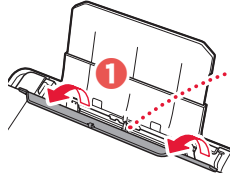

- 4 Kağıt yerleştirin.

- 2 veya daha fazla Letter veya A4 boyutunda düz kağıt yerleştirin.
- Yan kağıt kılavuzunu kağıt yığınının kenarına kaydırın.

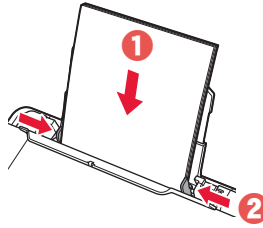

- 5 Besleme yuvası kapağını kapatın.

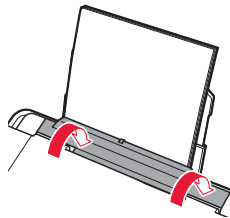

6 Kağıt çıkış tepsisini uzatın.

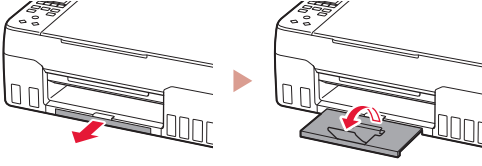

7 Ekrandaki yönergeleri izleyin ve ardından **OK** düğmesine basın.

Load 2 or more sheets of
[OK]Next



Adjusting for first use...
About █ min. remaining

- Aşağıdaki ekran görünene kadar lütfen biraz bekleyin.

Do you want to update at
< Yes > No



Setup is complete
[OK]



To connect to a computer
[OK]



Copy
100% █ 01

Yazıcıyı nasıl kullanacağınıza en uygun bağlantı yöntemini seçin.

- Diğer aygıtları bağlamadan yazıcıyı kullanmak için
➔ Kurulum şimdi tamamlandı.
- Yazıcıyı bilgisayara veya akıllı telefona bağlayarak kullanmak için
➔ Bir sonraki sayfaya geçin.

? Ekranında bir hata mesajı (destek kodu) belirirse

Protective material rema
Support code 1890

Destek kodu
(Support code)

Ekrandaki destek kodunu kontrol edin ve görüntülenen kod aşağıda yazıyorsa yönergeleri izleyin.

- 1890
Koruyucu malzeme kalmış.
➔ "2. Koruyucu Malzemeleri Çıkarma", sayfa 1
- 1470/1471
Yazıcı kafaları doğru takılmamış.
➔ "3. Yazıcı Kafalarını Takma", sayfa 1
- 1474
Yazıcı kafaları doğru takılmamış.
Mürekkep valfi kolunu kapatın, sonra sol ve sağ yazıcı kafalarını değiştirin.

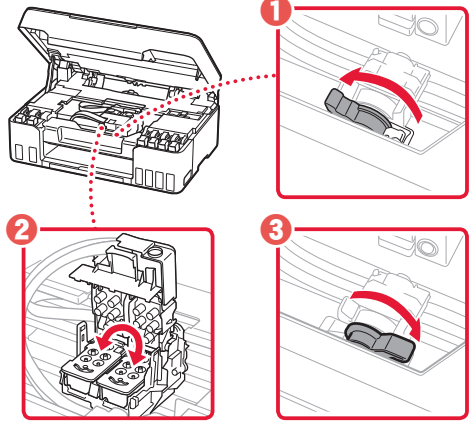

➔ "3. Yazıcı Kafalarını Takma", sayfa 1

- 5200
Mürekkep sistemi hazırlama başarıyla tamamlanmadı.
Yazıcıyı yeniden başlatmak için **Açma (ON)** düğmesine basın ve ardından "5. Mürekkebi Dökme", sayfa 3 bölümüne bakın.

Diğer tüm durumlar için bkz. **Çevrimiçi El Kitabı**.

Hangi aygıtı bağıyorsunuz?



Bilgisayar



Bilgisayar ve akıllı telefon





Akıllı telefon

7-a

Bilgisayara Bağlanma

Birden fazla bilgisayar kullanıyorsanız her bilgisayarda bu adımları gerçekleştirin.



- 1 Bilgisayarınızdan Canon web sitesine erişin.
 <https://ij.start.canon>
- 2  **Kurulum** seçeneğini belirleyin.
- 3 Yazıcınızın model adını girin ve **Git** ögesine tıklayın.
- 4 **Başlat** ögesine tıklayın.
- 5 **(B) Bilgisayara/Akıllı Telefona Bağlanma** ögesine tıklayın.
 - Aşağıdaki adımlar Windows kullanıcılarına yöneliktir.
- 6 **İndir** ögesine tıklayın.
- 7 İndirilen dosyayı çalıştırın.
 - Ekrandaki yönergeleri izleyin. Bu biraz zaman alabilir.
 - Akıllı telefona bağlamak için bkz. "7-b. Akıllı Telefona Bağlanma", sayfa 7.



Kurulum CD-ROM'unu Kullanma

CD-ROM'da **EasySetup.exe** ögesini çift tıklayın ve sonra 3. adımdan devam edin. İnternet bağlantınız yoksa, CD-ROM'da **win** klasörünü açın ve **SETUP.exe** ögesine çift tıklayın. Yazıcı sürücüsü yüklenecektir.

7-b

Akıllı Telefona Bağlanma

Birden fazla akıllı telefon kullanıyorsanız her telefonda bu adımları gerçekleştirin.



1 Akıllı telefonunuza "Canon PRINT Inkjet/SELPHY" özelliğini kurun.



- App Store veya Google Play üzerinde "Canon PRINT" araması yapın.
- Uygulamayı indirmek için Canon web sitesine gidin.



2 Akıllı telefonunuzda Wi-Fi ayarlarını açın. "Canon_ij_" ile başlayan ağ adının (SSID) görüldüğünden emin olun.

(iOS ekranı örneği)

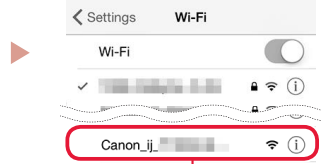

"Canon_ij_" ile başlayan ağ adı (SSID)

- "Canon_ij_" görünürse, → 3. adıma geçin.
- "Canon_ij_" görünmezse, → 4. adıma geçin.

3 "Canon_ij_" ile başlayan ağ adına (SSID) dokununuz.

4 Yüklü uygulamayı açın ve ardından yazıcınızı eklemek için uygulamada ekrandaki yönergeleri izleyin.



Yazıcınızı ekledikten sonra akıllı telefonunuzdan yazdırabilirsiniz.

Fotoğraf yazdırmak için bkz. "Fotoğraf Kağıdı Yerleştirme", sayfa 8.

Fotoğraf Kağıdı Yerleştirme

1 Kağıt desteğini uzatın.

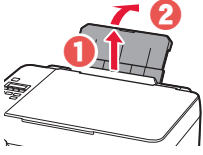

2 Besleme yuvası kapağını açın ve sağ kağıt kılavuzunu en sağa kaydırın.

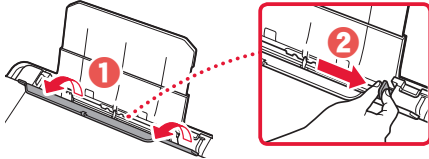

3 Birkaç sayfa fotoğraf kağıdını, yazdırılacak tarafı yukarı bakacak şekilde yükleyin ve yan kağıt kılavuzunu kaydırarak kağıt destesinin kenarına temas ettirin.

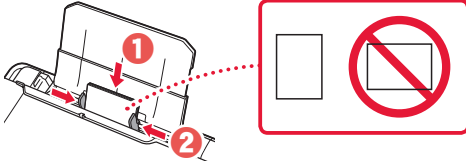

4 Besleme yuvası kapağını kapatın.

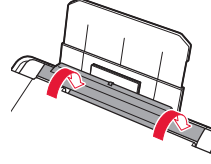

5 Yazıcının ekranında **Arka tepsi kağıt bilgilerini kaydet (Save the rear tray paper information)** görüldüğünde **OK** düğmesine basın.

6 Kağıt boyutu ve türünü seçip **OK** düğmesine basın.

7 Kağıt çıkış tepsisini uzatın.

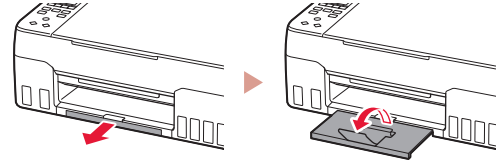

Yazıcınızı Taşıma

Yazıcıyı başka bir yere taşıırken aşağıdakileri kontrol edin. Ayrıntılar için **Çevrimiçi El Kitabı**'na bakın.

Mürekkebin akmasını engellemek için, her iki ek düğmesinin de tamamen basılı olduğundan emin olun.

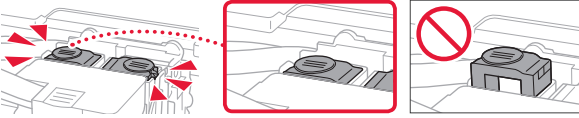

Mürekkep valfi kolunun kapalı konumunda olduğundan emin olun.

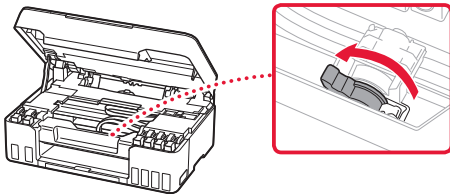

Mürekkep akıyorsa, yazıcıyı plastik bir poşetle paketleyin.

- Güvenli taşınması için yazıcıyı alt tarafı aşağı bakacak şekilde sağlam bir kutuya koyun ve yeterli miktarda koruyucu malzeme kullanın.
- Yazıcıyı eğmeyin. Mürekkep sızabilir.
- Lütfen dikkatli bir şekilde taşıyın ve kutunun düz tutulduğundan ve baş aşağı veya yana doğru çevrilmediğinden emin olun; aksi halde yazıcı hasar görebilir ve yazıcıdaki mürekkep sızabilir.
- Taşıma görevlisi yazıcıyı taşıırken, kutunun üst tarafına "ÜST TARAF" yazıldığından emin olun, bu sayede yazıcının alt tarafı üste gelecek şekilde konmadığından emin olabilirsiniz. Ayrıca "KIRILCAK EŞYA" veya "DİKKATLİ TAŞIYIN" yazın.

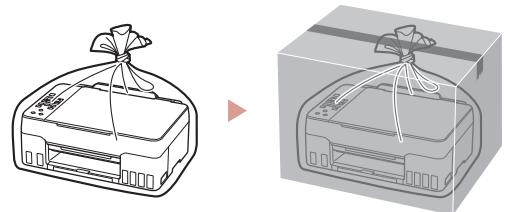

Configurarea imprimantei



**Pentru Configurare, vizitați
adresa URL**

<https://ij.start.canon>



sau scanați codul cu dispozitivul mobil

• Dacă nu aveți o conexiune la internet, urmați instrucțiunile de mai jos.

1. Conținutul cutiei

• Capete de imprimare

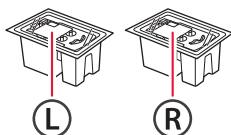

- Sticle de cerneală
- Cablu de alimentare
- CD-ROM de instalare
- Informații cu privire la siguranță și alte informații importante
- Ghid de inițiere (acest manual)

2. Îndepărtarea materialelor de ambalare



- 1 Îndepărtați și eliminați toate materialele de ambalare și banda portocalie.
- 2 Deschideți unitatea de scanare / capacul, îndepărtați și aruncați banda portocalie și materialul de protecție din interior.

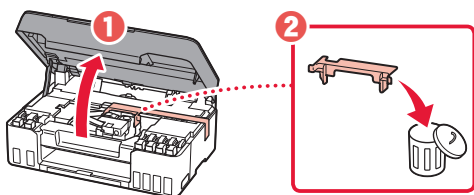

3. Instalarea capetelor de imprimare



- 1 Deschideți capacul de blocare a capului de imprimare.

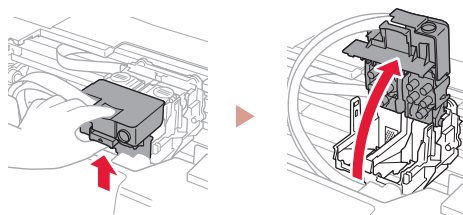

- 2 Scoateți fiecare cap de imprimare din ambalaj și îndepărtați eticheta.

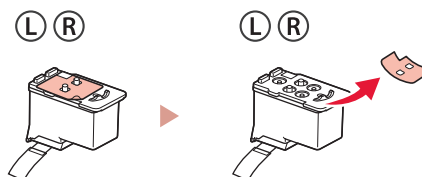

- 3 Îndepărtați banda portocalie.

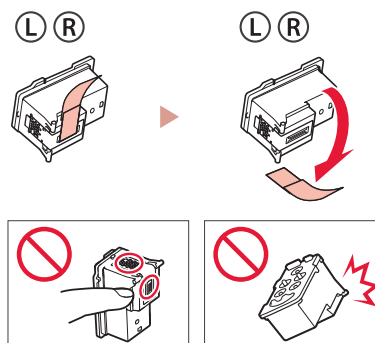

Configurarea imprimantei

- 4 Introduceți capul de imprimare L în partea stângă și capul de imprimare R în partea dreaptă.

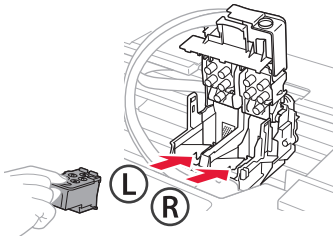

- 5 Închideți capacul de blocare a capului de imprimare și împingeți în jos până când se aude un clic.

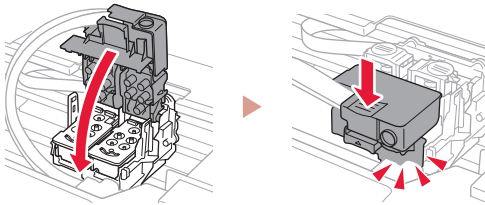

- 6 Apăsați în jos complet ambele butoane de îmbinare până se aude un clic.

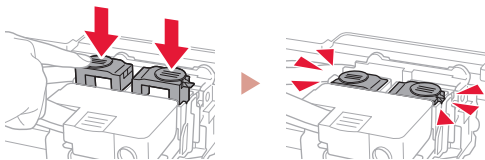

Verificați!

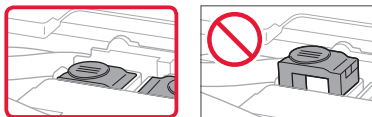

- 7 Închideți unitatea de scanare / capacul.
- Deschideți complet unitatea de scanare / capacul, apoi închideți.

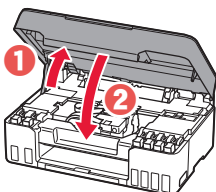

⚠ **Atenție**
Aveți grijă la degete.

4. Pornirea imprimantei



- 1 Conectați cablul de alimentare.

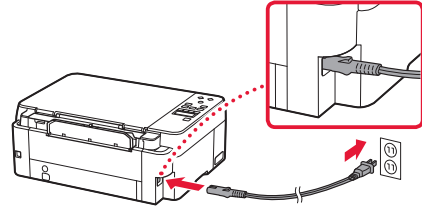

În spate

- 2 Apăsați butonul **ACTIVARE (ON)**.

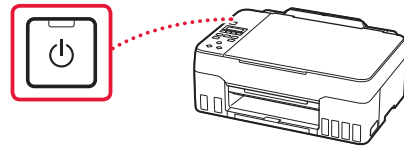

- 3 Când apare următorul ecran, folosiți butoanele ◀ și ▶ pentru a selecta o limbă, apoi apăsați butonul **OK**.



»»» Important

Dacă pe ecran apare o eroare, consultați „Dacă pe ecran apare un mesaj de eroare (cod suport)” la pagina 5 și urmați instrucțiunile.

5. Turnarea cernelii



►►► Important

Acest produs necesită o manevrare atentă a cernelii. Atunci când rezervoarele de cerneală sunt umplute cu cerneală, aceasta se poate împrăști. Dacă hainele sau obiectele dvs. sunt pătate cu cerneală, este posibil ca aceasta să nu poată fi îndepărtată.

1 Deschideți unitatea de scanare / capacul.

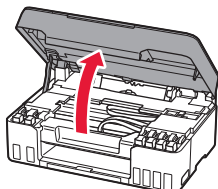

2 Deschideți capacul gri al rezervorului din partea stângă a imprimantei.

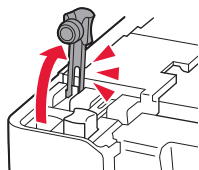

3 Țineți sticla de cerneală GY (gri) în poziție verticală și răsușiți ușor capacul sticlei pentru a-l scoate.

Verificați!

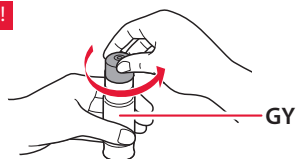

4 Aliniați duza sticlei de cerneală cu orificiul de umplere.

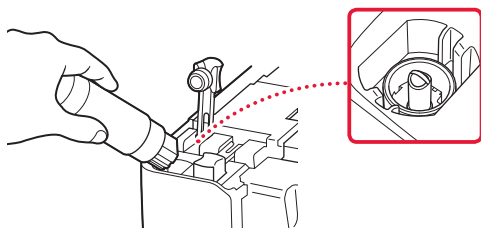

5 Răsturnați ușor sticla de cerneală și împingeți în jos pentru a turna cerneala.

- Dacă cerneala nu curge, îndepărtați ușor sticla de cerneală și încercați din nou.

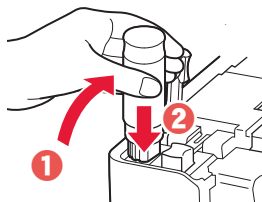

6 Scoateți ușor sticla de cerneală din orificiul de umplere.

- Aveți grijă să nu vărsați cerneala.

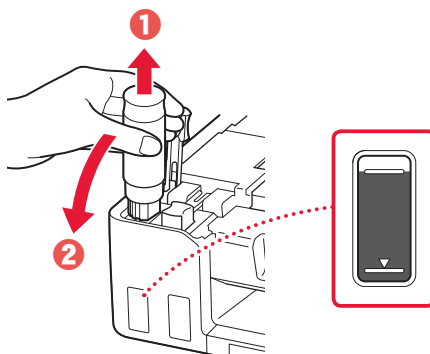

7 Așezați la loc în siguranță capacul rezervorului.

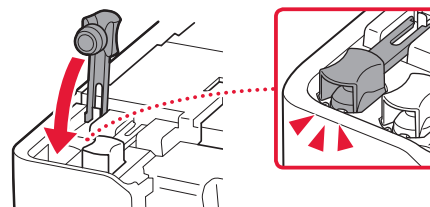

Configurarea imprimantei

- 8 Repetați pașii de la 2 până la 7 pentru a turna cerneala pentru toate culorile în rezervoarele de cerneală corespunzătoare.

- Turnați cerneala furnizată care corespunde culorii capacului rezervorului.

Verificați!

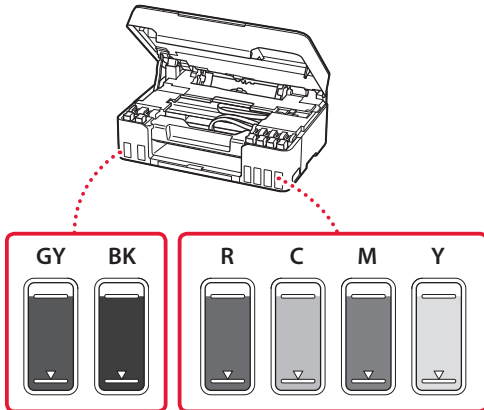

- 9 Închideți unitatea de scanare / capacul.

- Deschideți complet unitatea de scanare / capacul, apoi închideți.

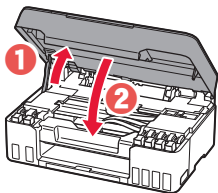

⚠ Atenție
Aveți grijă la degete.

- 10 Folosiți butoanele ◀ și ▶ pentru a selecta **Da (Yes)** și apoi apăsați butonul **OK**.

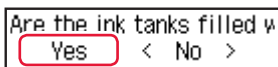

6. Încărcarea hârtiei



- 1 Folosiți butoanele ◀ și ▶ pentru a selecta **Da (Yes)** și apoi apăsați butonul **OK**.



- 2 Extindeți suportul pentru hârtie.

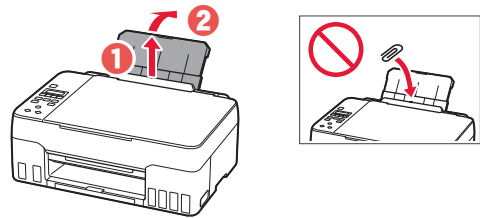

- 3 Deschideți capacul fantei de alimentare și glisați ghidajul pentru hârtie din partea dreaptă complet la dreapta.

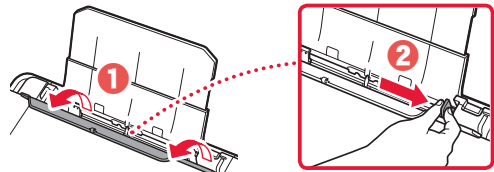

- 4 Încărcați hârtie.

- Încărcați 2 sau mai multe coli de hârtie simplă de dimensiune Letter sau A4.
- Glisați ghidajul pentru hârtie lateral de-a lungul marginii teancului de hârtie.

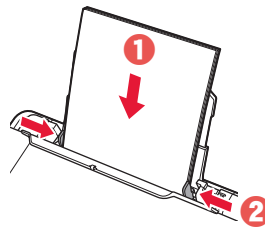

- 5 Închideți capacul fantei de alimentare.

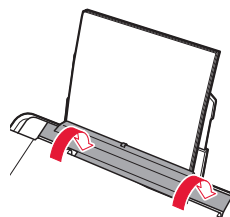

6 Extindeți tava de ieșire a hârtiei.

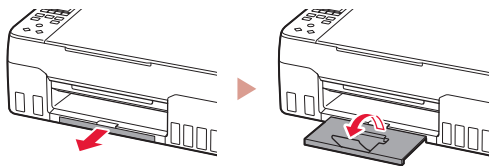

7 Urmați instrucțiunile de pe ecran, apoi apăsați butonul **OK**.

Load 2 or more sheets of
[OK]Next

Adjusting for first use...
About █ min. remaining

- Așteptați câteva momente până când apare ecranul următor.

Do you want to update it
< Yes > No

Setup is complete [OK]

To connect to a computer [OK]

Copy
100% █ 01

Selecționați metoda de conectare care se potrivește cel mai bine cu modul în care veți utiliza imprimanta.

- Pentru a utiliza imprimanta fără a o conecta la alte dispozitive
➔ Configurarea este acum finalizată.
- Pentru a utiliza imprimanta prin conectarea la un computer sau smartphone
➔ Continuați la pagina următoare.

? Dacă pe ecran apare un mesaj de eroare (cod suport)

Protective material rema
Support code 1890 Cod suport
(Support code)

Verificați cod suport, apoi urmați instrucțiunile, dacă codul afișat este scris mai jos.

- 1890
Materialul de protecție nu a fost îndepărtat complet.
➔ „2. Îndepărtarea materialelor de ambalare” la pagina 1
- 1470/1471
Capetele de imprimare nu sunt instalate corect.
➔ „3. Instalarea capetelor de imprimare” la pagina 1
- 1474
Capetele de imprimare nu sunt instalate corect.
Închideți pârghia supapei de cerneală și schimbați capetele de imprimare din dreapta și stânga între ele.

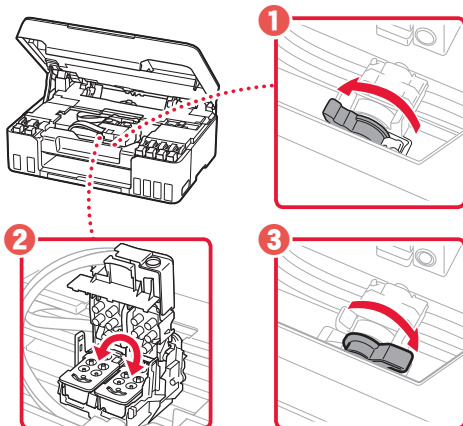

➔ „3. Instalarea capetelor de imprimare” la pagina 1

- 5200
Pregătirea sistemului de cerneală nu a fost finalizată cu succes.
Apăsați pe butonul **ACTIVARE (ON)** pentru a reporni imprimanta, apoi consultați „5. Turnarea cernelei” la pagina 3.

Pentru toate celelalte situații, consultați **Manual online**.

Ce dispozitiv conectați?



Computer



Computer și
smartphone





Smartphone

7-a

Conectarea la un computer

Dacă folosiți mai multe computere, efectuați pașii următori pe fiecare computer.



- 1 Accesați site-ul web Canon de pe computerul dvs.
 <https://ij.start.canon>
- 2 Selectați  **Configurarea**.
- 3 Introduceți numele modelului imprimantei dvs. și faceți clic pe **Accesați**.
- 4 Faceți clic pe **Pornire**.
- 5 Faceți clic pe **(B) Conectarea la un computer/smartphone**.
 - Pașii următori sunt pentru utilizatorii de Windows.
- 6 Faceți clic pe **Descărcare**.
- 7 Executați fișierul descărcat.
 - Urmăriți instrucțiunile de pe ecran. Acest lucru poate dura mai mult timp.
 - Pentru a conecta și un smartphone, consultați „7-b. Conectarea la un smartphone” la pagina 7.



Utilizarea CD-ROM-ului de instalare

Faceți dublu clic pe **EasySetup.exe** de pe CD-ROM, apoi continuați de la pasul 3. Dacă nu aveți o conexiune la internet, deschideți folderul **win** de pe CD-ROM și faceți dublu clic pe **SETUP.exe**. Acesta va începe instalarea driverului de imprimantă.

7-b

Conectarea la un smartphone

Dacă folosiți mai multe dispozitive smartphone, efectuați pașii următori pe fiecare smartphone.



1 Instalați aplicația „Canon PRINT Inkjet/SELPHY” pe smartphone.



- Căutați „Canon PRINT” în App Store sau Google Play.
- Accesați site-ul web Canon pentru a descărca aplicația.



2 Deschideți setările Wi-Fi ale smartphone-ului. Verificați dacă apare numele rețelei (SSID) care începe cu „Canon_ij_”.

(Exemplu de ecran iOS)

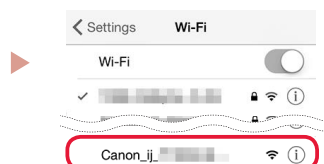

Numele rețelei (SSID) care începe cu „Canon_ij_”

- Dacă apare „Canon_ij_” → Continuați cu pasul **3**.
- Dacă nu apare „Canon_ij_” → Continuați cu pasul **4**.

3 Atingeți numele rețelei (SSID) care începe cu „Canon_ij_”.

4 Deschideți aplicația instalată și apoi urmați instrucțiunile de pe ecran din aplicație pentru a vă adăuga imprimanta.

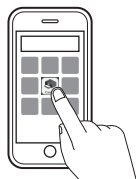

După ce ați adăugat imprimanta, puteți imprima de pe smartphone.
Pentru a imprima fotografii, consultați „Încărcarea hârtiei foto” la pagina 8.

Încărcarea hârtiei foto

1 Extindeți suportul pentru hârtie.

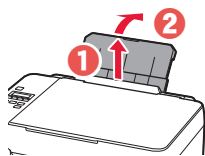

2 Deschideți capacul fantei de alimentare și glisați ghidajul pentru hârtie din partea dreaptă complet la dreapta.

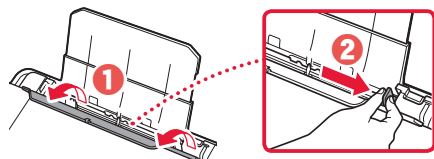

3 Încărcați mai multe coli de hârtie foto cu fața de imprimare orientată în sus și glisați ghidajul pentru hârtie lateral spre marginea stivei de hârtie.

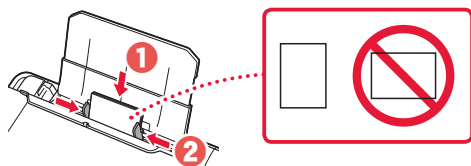

4 Închideți capacul fantei de alimentare.

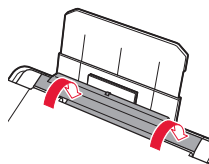

5 Atunci când **Înregistrați informațiile despre hârtia din tava din spate (Save the rear tray paper information)** apare pe ecranul imprimantei, apăsați butonul **OK**.

6 Selectați dimensiunea și tipul hârtiei, apoi apăsați butonul **OK**.

7 Extindeți tava de ieșire a hârtiei.

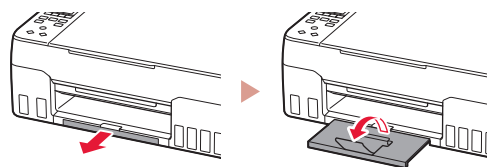

Transportul imprimantei

Când schimbați locul de amplasare a imprimantei, verificați următoarele. Pentru detalii, consultați **Manual online**.

Asigurați-vă că ambele butoane de îmbinare sunt apăstate complet, pentru a evita scurgerile de cerneală.

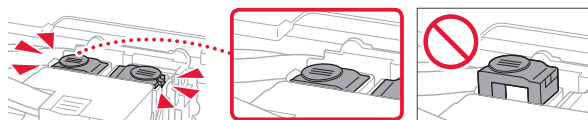

Verificați dacă pârghia supapei de cerneală se află în poziție închisă.

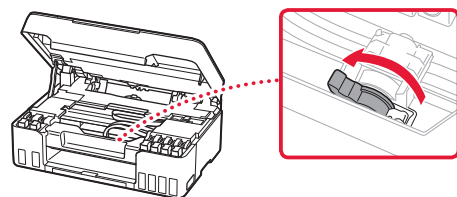

În cazul în care există scurgeri de cerneală, împachetați imprimanta într-o pungă de plastic.

- Ambalați imprimanta într-o cutie solidă astfel încât să fie așezată cu baza în jos, utilizând material de protecție suficient pentru a asigura transportul în siguranță.
- Nu înclinați imprimanta. Se poate scurge cerneală.
- Manevrați cu grijă și asigurați-vă că cutia rămâne plană și **NU** întoarsă cu fața în jos sau pe laterale, deoarece imprimanta se poate deteriora și cerneala din imprimantă se poate scurge.
- Când un agent de livrări manevrează transportul imprimantei, cutia acesteia trebuie să fie marcată „**CU PARTEA ACEASTA ÎN SUS**” pentru a menține imprimanta cu baza în jos. De asemenea, marcați cu „**FRAGIL**” sau „**MANEVRAȚI CU ATENȚIE**”.

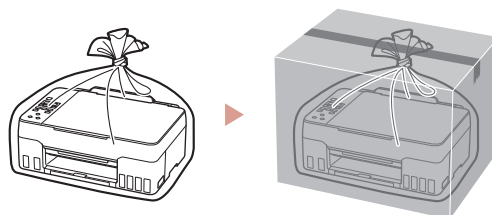

Настройване на принтера



За настройка посетете URL адреса

<https://ij.start.canon>



или сканирайте кода с мобилното си устройство

● Следвайте инструкциите по-долу, ако нямате интернет връзка.

1. Съдържание на комплекта

● Печатащи глави

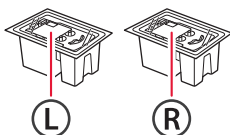

- Бутилки с мастило
- Захранващ кабел
- Инсталационен компактдиск
- Информация за безопасността и важна информация
- Ръководство за начално запознаване (това ръководство)

2. Отстраняване на опаковъчните материали



- 1 Отстранете и изхвърлете всички опаковъчни материали и оранжевата лепенка.
- 2 Отворете сканиращия модул/капака, отстранете отвътре оранжевата лепенка и предпазния материал и ги изхвърлете.

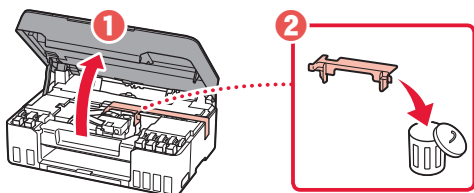

3. Поставяне на печатащите глави



- 1 Отворете застопоряващия капак на печатащата глава.

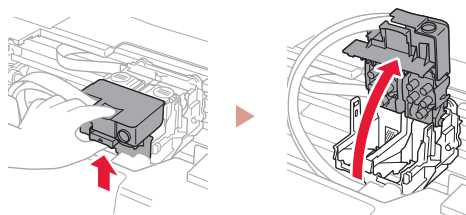

- 2 Извадете всяка от печатащите глави от опаковката и отстранете етикета.

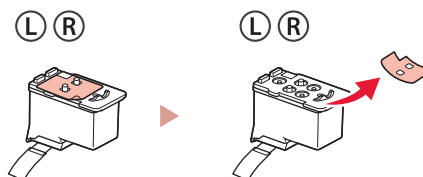

- 3 Отстранете оранжевата лепенка.

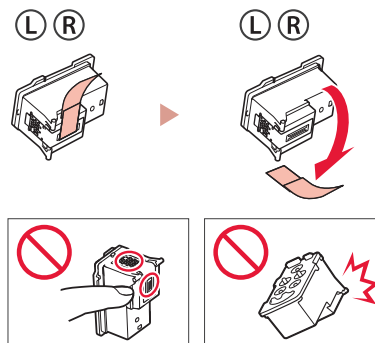

Настройване на принтера

- 4 Поставете печатащата глава L отляво и печатащата глава R отдясно.

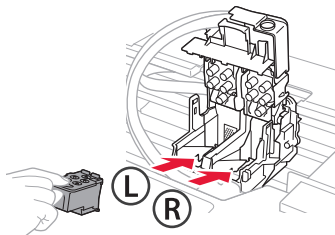

- 5 Затворете застопоряващия капак на печатащата глава и натиснете надолу, докато щракне.

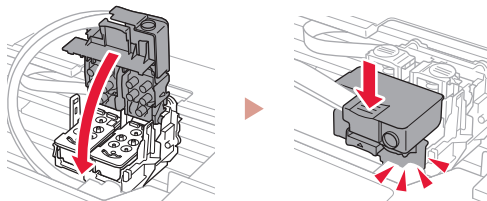

- 6 Натиснете докрай надолу двата бутона за свързване, докато щракнат.

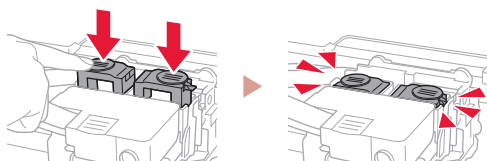

Проверете!

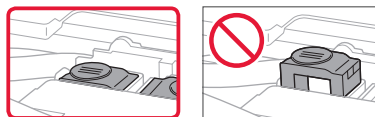

- 7 Затворете сканиращия модул/капака.

- Отворете сканиращия модул/капака докрай и след това го затворете.

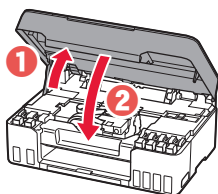

⚠ Внимание

Пазете пръстите си.

4. Включване на принтера



- 1 Свържете захранващия кабел.

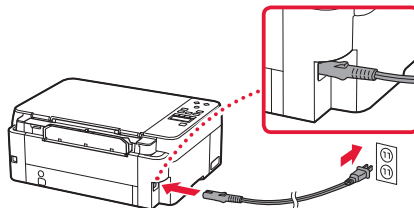

Отзад

- 2 Натиснете бутона **Включване (ON)**.

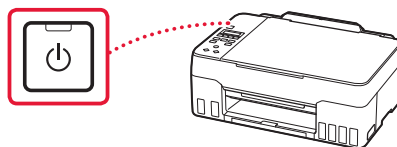

- 3 Когато се покаже следният екран, използвайте бутоните ◀ и ▶, за да изберете език, след което натиснете бутона **OK**.



»»» Важно

Ако на екрана се покаже грешка, вижте „Ако на екрана се покаже съобщение за грешка (код за поддръжка)“ на стр. 5 и следвайте инструкциите.

5. Наливане на мастило



Важно

Този продукт изисква внимателно боравене с мастилото. То може да се разгръска при напълване на резервоарите за мастило. Ако по дрехите или вещите ви попадне мастило, може да не се изчисти.

1 Отворете сканиращия модул/капака.

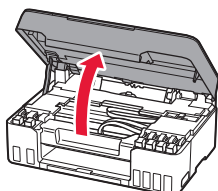

2 Отворете сивата капачка на резервоара отляво на принтера.

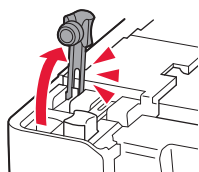

3 Дръжте бутилката с мастило GY (сива) изправена и внимателно завъртете капачката на бутилката, за да я свалите.

Проверете!

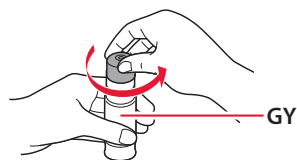

4 Подравнете накрайника на бутилката с мастило към входния отвор.

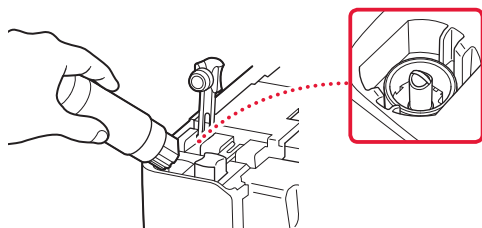

5 Бавно обърнете обратно и изправете бутилката с мастило, след което я натиснете надолу, за да налеее мастилото.

- Ако мастилото не се налива, внимателно извадете бутилката с мастило и опитайте отново.

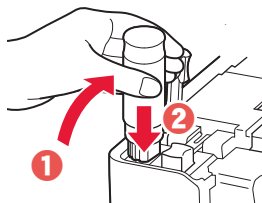

6 Внимателно извадете бутилката с мастило от входния отвор.

- Внимавайте да не разлеее мастило.

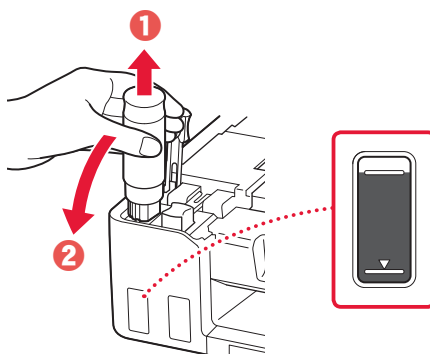

7 Поставете **добре** капачката на резервоара обратно на мястото й.

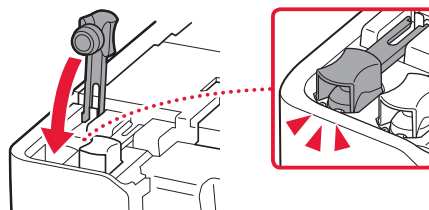

Настройване на принтера

8 Повторете стъпки от 2 до 7, за да налеее цялото количество мастило за всички цветове в съответните резервоари за мастило.

- Налейте доставеното мастило, което съответства на цвета на капачката на резервоара.

Проверете!

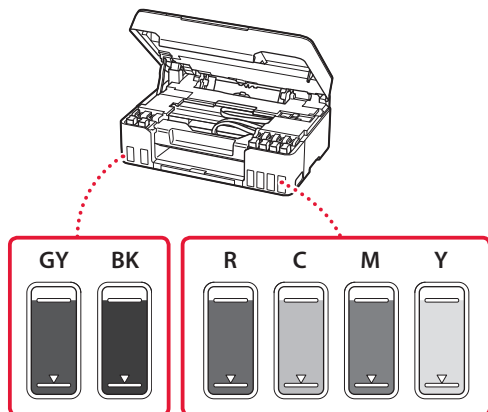

9 Затворете сканиращия модул/капака.

- Отворете сканиращия модул/капака докрай и след това го затворете.

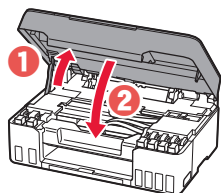

Внимание

Пазете пръстите си.

10 С помощта на бутоните ◀ и ▶ изберете **Да (Yes)**, след което натиснете бутона **ОК**.

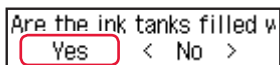

6. Зареждане на хартия



1 С помощта на бутоните ◀ и ▶ изберете **Да (Yes)**, след което натиснете бутона **ОК**.



2 Изтеглете подложката за хартия.

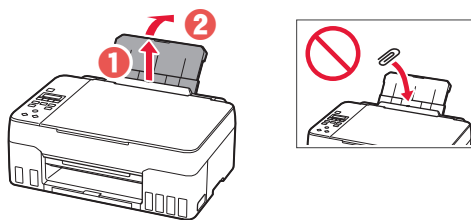

3 Отворете капака на гнездото за подаване и плъзнете десния водач за хартия докрай надясно.

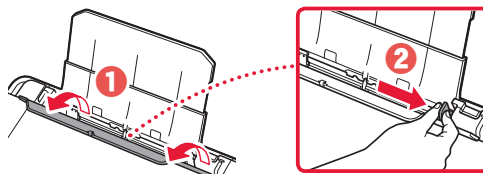

4 Заредете хартия.

- Заредете 2 или повече листа обикновена хартия с размер Letter или A4.
- Плъзнете страничния водач за хартия до ръба на топчето хартия.

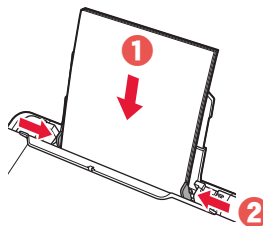

5 Затворете капака на гнездото за подаване.

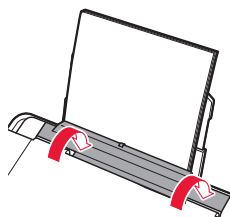

6 Изтеглете изходната тава за хартия.

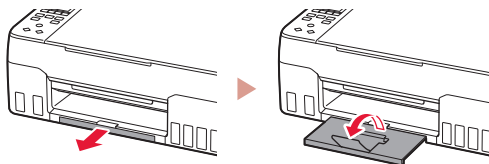

7 Следвайте инструкциите на екрана и след това натиснете бутона **OK**.

Load 2 or more sheets of
[OK]Next

Adjusting for first use...
About █ min. remaining

- Изчакайте малко, докато се покаже следният екран.

Do you want to update at
< Yes > No

Setup is complete [OK]

To connect to a computer [OK]

Copy
100% █ 01

Изберете метода на свързване, който най-добре съответства на начина, по който ще използвате принтера.

- За използване на принтера без свързване с други устройства
 - ➔ Настройката е завършена.
- За използване на принтера чрез свързване с компютър или смартфон
 - ➔ Преминете на следващата страница.

? Ако на екрана се покаже съобщение за грешка (код за поддръжка)

Protective material rema
Support code 1890

Код за поддр.
(Support code)

Проверете кода за поддръжка, след което следвайте инструкциите, ако показаният код е посочен по-долу.

- 1890
Останал е предпазен материал.
➔ „2. Отстраняване на опаковъчните материали“ на стр. 1
- 1470/1471
Печатащите глави не са поставени правилно.
➔ „3. Поставяне на печатащите глави“ на стр. 1
- 1474
Печатащите глави не са поставени правилно.
Затворете лоста за мастиления клапан и разменете лявата и дясната печатащи глави.

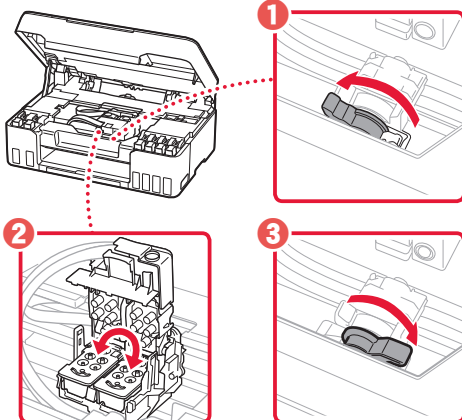

➔ „3. Поставяне на печатащите глави“ на стр. 1

- 5200
Подготовката на системата за мастило не е завършена успешно.
Натиснете бутона **Включване (ON)**, за да рестартирате принтера, след което вижте „5. Наливане на мастило“ на стр. 3.

За всички други случаи вижте **Онлайн ръководство**.

Какво устройство свързвате?



Компютър



Компютър и
смартфон





Смартфон

7-а

Свързване с компютър

Ако използвате няколко компютъра, извършете тези стъпки на всеки от тях.



- 1 Влезте в уебсайта на Canon от своя компютър.
 <https://ij.start.canon>
- 2 Изберете  **Настройка**.
- 3 Въведете името на модела на принтера и щракнете върху **Старт**.
- 4 Щракнете върху **Старт**.
- 5 Щракнете върху **(B) Свързване с компютър/смартфон**.
 - Следните стъпки са за потребители на Windows.
- 6 Щракнете върху **Изтегли**.
- 7 Стартирайте изтегления файл.
 - Следвайте инструкциите на екрана. Това може да отнеме известно време.
 - За да свържете също и със смартфон, вижте „7-b. Свързване със смартфон“ на стр. 7.



Използване на инсталационния компактдиск

Щракнете двукратно върху **EasySetup.exe** в компактдиска и след това продължете от стъпка 3. Ако нямате интернет връзка, отворете папката **win** в компактдиска и щракнете двукратно върху **SETUP.exe**. Това ще инсталира драйвера на принтера.

7-b

Свързване със смартфон

Ако използвате няколко смартфона, извършете тези стъпки на всеки от тях.



1 Инсталирайте приложението „Canon PRINT Inkjet/SELPHY“ на смартфона.



- Потърсете „Canon PRINT“ в App Store или Google Play.
- Посетете уебсайта на Canon, за да изтеглите приложението.



2 Отворете настройките за Wi-Fi на смартфона си. Проверете дали се показва името на мрежата (SSID), което започва с „Canon_ij_“.

(Пример за екран на iOS)

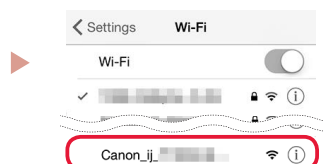

Името на мрежата (SSID), което започва с „Canon_ij_“

- Ако „Canon_ij_“ се показва, → продължете към стъпка 3.
- Ако „Canon_ij_“ не се показва, → продължете към стъпка 4.

3 Докоснете името на мрежата (SSID), което започва с „Canon_ij_“.

4 Отворете инсталираното приложение и следвайте инструкциите на екрана в него, за да добавите принтера.



След като добавите принтера, можете да печатате от смартфона.

За отпечатване на снимки вижте „Зареждане на фотохартия“ на стр. 8.

Зареждане на фотохартия

- 1 Изтеглете подложката за хартия.

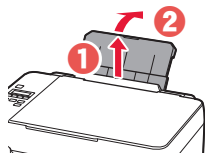

- 2 Отворете капака на гнездото за подаване и плъзнете десния водач за хартия докрай надясно.

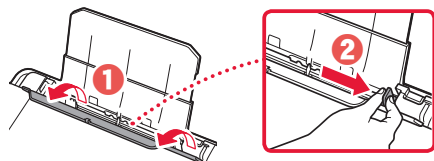

- 3 Заредете няколко листа фотохартия със страната за печат нагоре и плъзнете страничния водач за хартия до ръба на топчето хартия.

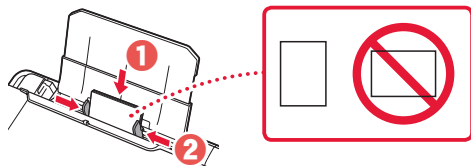

- 4 Затворете капака на гнездото за подаване.

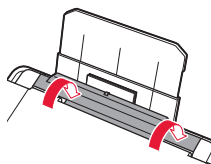

- 5 Когато на екрана на принтера се покаже **Регистриране на информация за хартията в задната тава (Save the rear tray paper information)**, натиснете бутона **OK**.

- 6 Изберете размера и типа на хартията и натиснете бутона **OK**.

- 7 Изтеглете изходната тава за хартия.

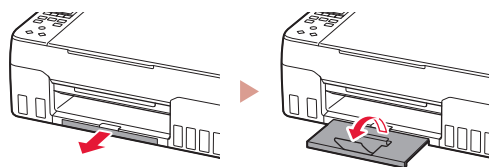

Транспортиране на принтера

Когато премествате принтера, проверете следното. За подробности вижте **Онлайн ръководство**.

Проверете дали и двата бутона за свързване са натиснати докрай надолу, за да избегнете течове на мастило.

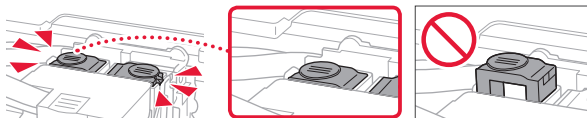

Проверете дали лостът за мастиления клапан е в затворено положение.

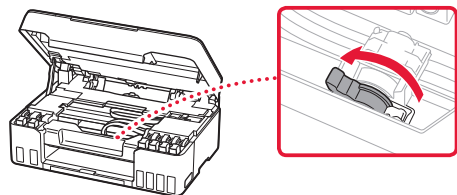

Опакувайте принтера в найлонов чувал, в случай че протече мастило.

- Опакувайте принтера в твърд кашон, така че да е поставен с долната част надолу, като използвате достатъчно предпазен материал, за да осигурите безопасното му транспортиране.
- Не наклоняйте принтера. Мастилото може да протече.
- Работете внимателно и се уверете, че кашонът винаги остава в хоризонтално положение и НЕ се обръща обратно или настрани, тъй като принтерът може да се повреди и от него да изтече мастило.
- Когато използвате спедиторска фирма за транспортиране на принтера, обозначете кашона с надпис „ТАЗИ СТРАНА НАГОРЕ“, за да се уверите, че принтерът ще бъде поставян с долната му част надолу. Също така го обозначете с надпис „ЧУПЛИВО“ или „ДА СЕ БОРАВИ ВНИМАТЕЛНО“.

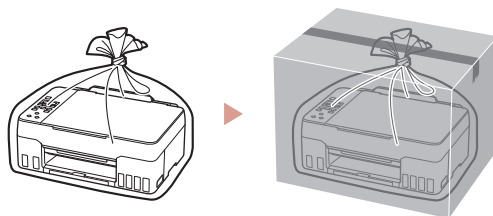

Nameščanje tiskalnika



Za nastavitev odprite URL

<https://ij.start.canon>



ali optično preberite kodo z mobilno napravo

• Če nimate internetne povezave, sledite navodilom spodaj.

1. Vsebina kompleta

• Tiskalne glave

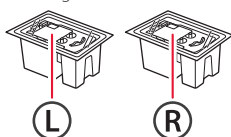

- Stekleničke s črnilom
- Napajalni kabel
- Namestitveni CD
- Informacije o varnosti in pomembne informacije
- Navodila za postavitve in začetek uporabe (ta priročnik)

2. Odstranjevanje zaščitnih materialov



- 1 Odstranite in zavržite vso embalažo in oranžni trak.
- 2 Odprite enoto za optično branje/pokrov ter odstranite in zavržite oranžni trak in notranji zaščitni material.

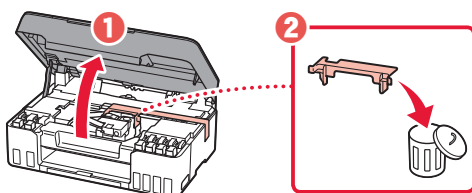

3. Namestitev tiskalnih glav



- 1 Odprite pokrov za pritrjevanje tiskalne glave.

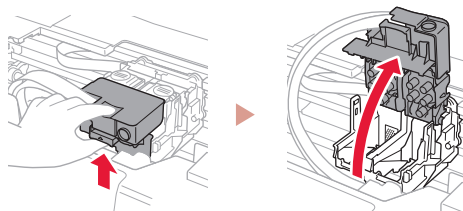

- 2 Vzemite posamezne tiskalne glave iz paketa in odstranite oznako.

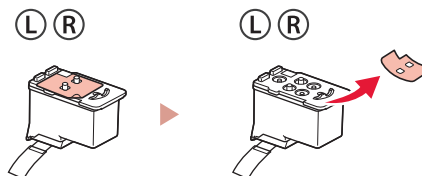

- 3 Odstranite oranžni trak.

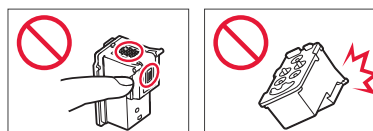
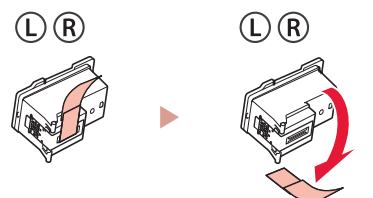

Nameščanje tiskalnika

- 4 Vstavite tiskalno glavo L na levo stran in tiskalno glavo R na desno stran.

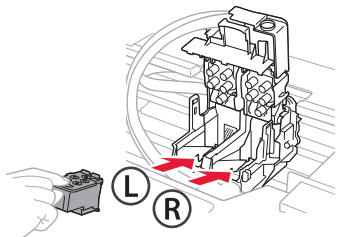

- 5 Zaprite pokrov za pritrdjevanje tiskalne glave in pritisnite navzdol, da se zaskoči.

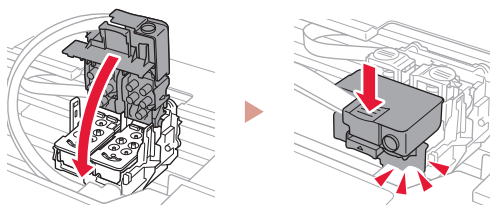

- 6 Gumba za spajanje potisnite povsem navzdol, da se zaskočita.

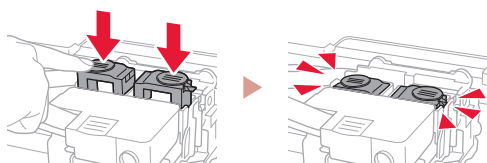

Preverite!

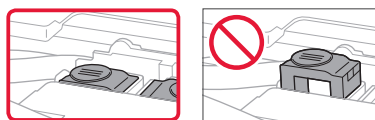

- 7 Zaprite enoto za optično branje/pokrov.
- Popolnoma odprite enoto za optično branje/pokrov in jo nato zaprite.

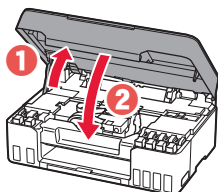

⚠ Pozor
Pazite na prste.

4. Vklp tiskalnika



- 1 Priključite napajalni kabel.

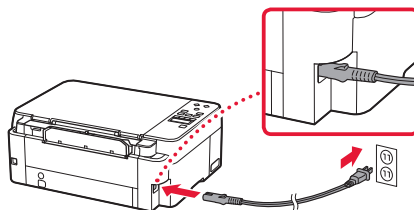

Zadaj

- 2 Pritisnite gumb **VKLOP (ON)**.

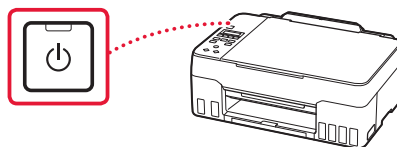

- 3 Ko se prikaže naslednji zaslon, z gumboma ◀ in ▶ izberite jezik, nato pa pritisnite gumb **OK**.



»»» Pomembno

Če se na zaslonu prikaže napaka, glejte razdelek »Če je na zaslonu prikazano sporočilo o napaki (koda za podporo)« na strani 5 in upoštevajte navodila.

5. Nalivanje črnila



»»» Pomembno

Ta izdelek zahteva previdno ravnanje s črnilom. Pri polnjenju črnilnih vložkov s črnilom se lahko to razmaže. Če se črnilo razmaže po oblačilih ali drugih predmetih, ga morda ne boste mogli odstraniti.

1 Odprite enoto za optično branje/pokrov.

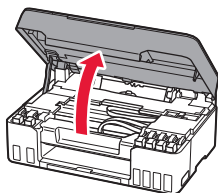

2 Odprite sivi pokrovček vložka na levi strani tiskalnika.

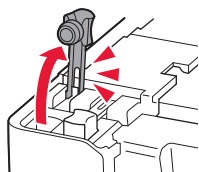

3 Stekleničko s črnilom GY (siva) držite pokonci in previdno zavrtite pokrovček stekleničke, da ga odstranite.

Preverite!

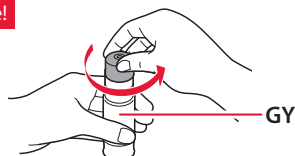

4 Šobo stekleničke s črnilom poravnajte z odprtino za dovajanje.

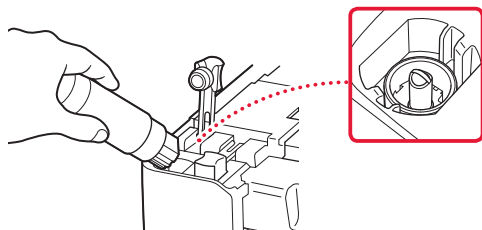

5 Stekleničko s črnilom počasi obrnite na glavo in potisnite navzdol, da nalijete črnilo.

- Če se črnilo ne iztoči, previdno odstranite stekleničko s črnilom in poskusite znova.

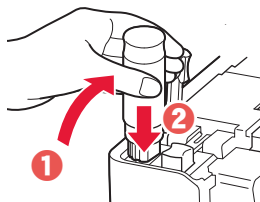

6 Stekleničko s črnilom previdno odstranite iz odprtine za dovajanje.

- Pazite, da črnila ne polijete.

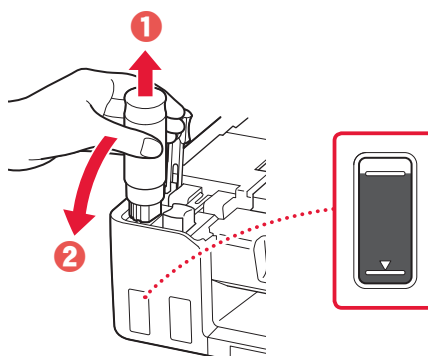

7 Znova **trdno** namestite pokrovček vložka.

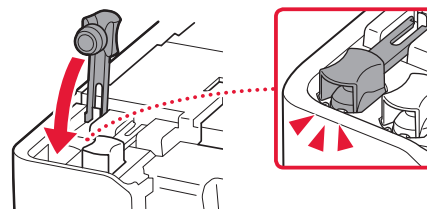

Nameščanje tiskalnika

8 Ponovite korake 2.–7., da vse črnilo za vse barve vlijete v ustrezne črnilne vložke za vsako barvo.

- Nalijte priloženo črnilo, ki ustreza barvi pokrovčka vložka.

Preverite!

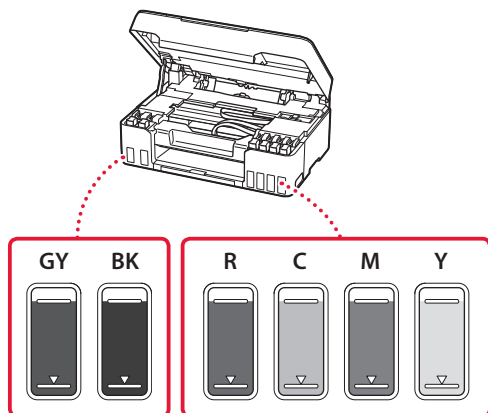

9 Zaprite enoto za optično branje/pokrov.

- Popolnoma odprite enoto za optično branje/pokrov in jo nato zaprite.

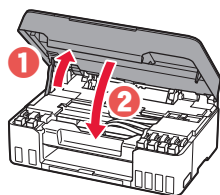

⚠ Pozor
Pazite na prste.

10 Z gumboma ◀ in ▶ izberite **Da (Yes)**, nato pa pritisnite gumb **OK**.

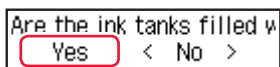

6. Nalaganje papirja



1 Z gumboma ◀ in ▶ izberite **Da (Yes)**, nato pa pritisnite gumb **OK**.



2 Razširite oporo za papir.

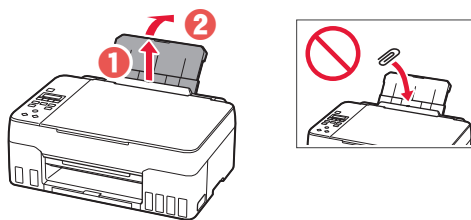

3 Odprite pokrov podajalne reže in desno vodilo za papir potisnite do konca v desno.

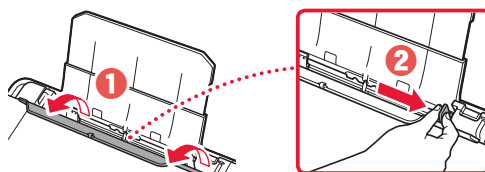

4 Vstavite papir.

- Vstavite 2 ali več listov navadnega papirja velikosti Letter ali A4.
- Potisnite stransko vodilo za papir ob rob svežnja papirja.

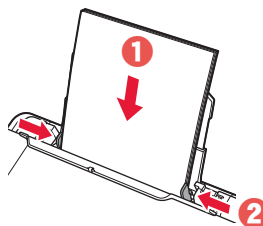

5 Zaprite pokrov podajalne reže.

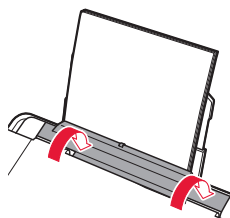

6 Razširite izhodni pladenj za papir.

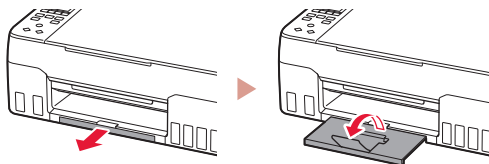

7 Upoštevajte navodila na zaslону in nato pritisnite gumb **OK**.

Load 2 or more sheets of
[OK]Next



Adjusting for first use...
About █ min. remaining

- Počakajte trenutek, dokler se ne prikaže naslednji zaslon.

Do you want to update at
< Yes > No



Setup is complete [OK]



To connect to a computer [OK]



Copy
100% █ 01

Izberite način povezave, ki najbolj ustreza temu, kako boste uporabljali tiskalnik.

- Če želite tiskalnik uporabljati brez povezave z drugimi napravami
➔ Nastavitev je zdaj dokončana.
- Če želite tiskalnik uporabljati tako, da ga povežete z računalnikom ali pametnim telefonom
➔ Nadaljujte na naslednji strani.

? Če je na zaslonu prikazano sporočilo o napaki (koda za podporo)

Protective material rema
Support code 1890

Koda za podp.
(Support code)

Preverite koda za podporo in upoštevajte navodila, če je prikazana koda navedena spodaj.

- 1890
Zaščitni material je ostal neodstranjen.
➔ »2. Odstranjevanje zaščitnih materialov« na strani 1
- 1470/1471
Tiskalne glave niso pravilno nameščene.
➔ »3. Namestitev tiskalnih glav« na strani 1
- 1474
Tiskalne glave niso pravilno nameščene.
Zaprte ročico ventila za črnilo in zamenjajte levo in desno tiskalno glavo.

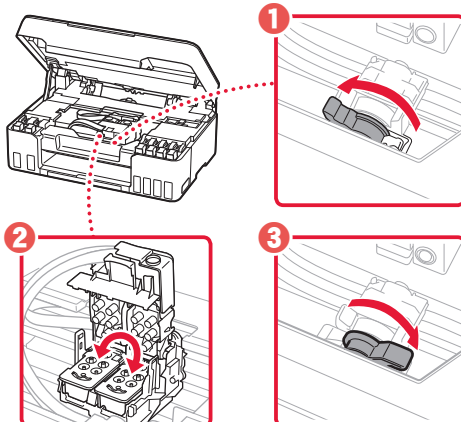

➔ »3. Namestitev tiskalnih glav« na strani 1

- 5200
Priprava sistema črnila ni bila uspešno dokončana.
Pritisnite gumb **VKLOP (ON)** za ponovni zagon tiskalnika, nato pa si oglejte »5. Nalivanje črnila« na strani 3.

Za vse druge primere glejte **Spletni priročnik**.

Katero napravo želite povezati?



Računalnik



Računalnik in pametni telefon





Pametni telefon

7-a

Vzpostavljanje povezave z računalnikom

Če uporabljate več računalnikov, te korake izvedite za vsakega od njih.



- 1 V računalniku odprite spletno mesto družbe Canon.
 <https://ij.start.canon>
- 2 Izberite  **Nastavitev**.
- 3 Vnesite ime modela tiskalnika in kliknite **Pojdi**.
- 4 Kliknite **Začni**.
- 5 Kliknite **(B) Vzpostavljanje povezave z računalnikom/pametnim telefonom**.
 - Naslednji koraki so za uporabnike sistema Windows.
- 6 Kliknite **Prenesi**.
- 7 Zaženite preneseno datoteko.
 - Sledite navodilom na zaslonu. To lahko traja nekaj časa.
 - Če se želite povezati tudi s pametnim telefonom, glejte »7-b. Povezovanje s pametnim telefonom« na strani 7.



Uporaba namestitvenega CD-ja

Na CD-ROM-u dvokliknite **EasySetup.exe** in nato nadaljujte na koraku 3. Če spletna povezava ni vzpostavljena, na CD-ju odprite mapo **win** in dvokliknite **SETUP.exe**. Tako boste namestili gonilnik tiskalnika.

7-b

Povezovanje s pametnim telefonom

Če uporabljate več pametnih telefonov, te korake izvedite za vsakega od njih.



1 V svojem pametnem telefonu namestite aplikacijo »Canon PRINT Inkjet/SELPHY«.



- V trgovini App Store ali Google Play poiščite »Canon PRINT«.
- Za prenos aplikacije odprite spletno mesto družbe Canon.



2 V pametnem telefonu odprite nastavitve Wi-Fi. Preverite, ali se ime omrežja (SSID), ki se začne s »Canon_ij_«, prikaže.

(Primer zaslona iOS)

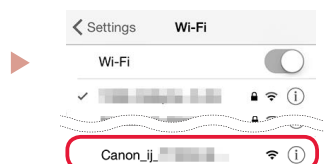

Ime omrežja (SSID) ki se začne s »Canon_ij_«

- Če se prikaže »Canon_ij_«, → nadaljujte s **3.** korakom.
- Če se »Canon_ij_« ne prikaže → nadaljujte s **4.** korakom.

3 Tapnite ime omrežja (SSID) ki se začne s »Canon_ij_«.

4 Odprite nameščeno aplikacijo, nato pa upoštevajte navodila na zaslonu aplikacije, da dodate tiskalnik.

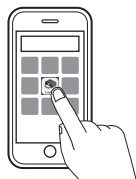

Ko dodate tiskalnik, lahko tiskate iz pametnega telefona.

Za tiskanje fotografij glejte »Nalaganje fotografskega papirja« na strani 8.

Nalaganje fotografskega papirja

1 Razširite oporo za papir.

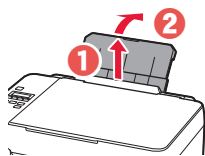

2 Odprite pokrov podajalne reže in desno vodilo za papir potisnite do konca v desno.

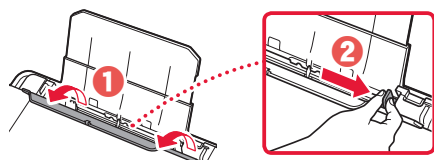

3 Naložite več listov fotografskega papirja s stranjo za tiskanje obrnjeno navzgor, nato pa stransko vodilo za papir potisnite ob rob svežnja papirja.

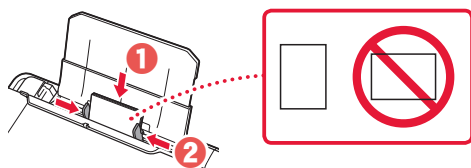

4 Zaprite pokrov podajalne reže.

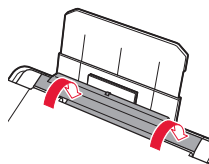

5 Ko se na zaslonu tiskalnika prikaže **Registrirajte informacije o papirju v zadnjem pladnju (Save the rear tray paper information)**, pritisnite gumb **OK**.

6 Izberite velikost in vrsto papirja ter pritisnite gumb **OK**.

7 Razširite izhodni pladenj za papir.

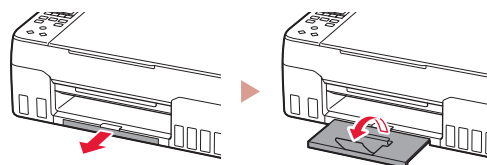

Prevoz tiskalnika

Ko premeščate tiskalnik, preverite spodnje trditve. Za podrobnosti glejte **Spletni priročnik**.

Prepričajte se, da sta oba gumba za spajanje pritisnjena povsem navzdol, da preprečite puščanje črnila.

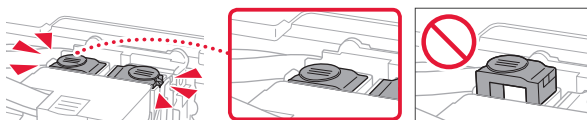

Preverite, ali je ročica ventila za črnilo v zaprtem položaju.

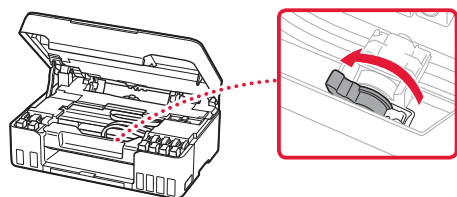

Tiskalnik vstavite v plastično vrečko za primer, da bi črnilo puščalo.

- Tiskalnik shranite v trdno škatlo tako, da je s spodnjim delom obrnjen navzdol. Uporabite dovolj zaščitnega materiala, da bo prenašanje varno.
- Tiskalnika ne nagibajte. Črnilo lahko izteče.
- Ravnajte previdno in škatlo položite na dno, NE na glavo ali na stranice, saj se lahko tiskalnik poškoduje ali začne iztekati črnilo v notranjosti tiskalnika.
- Preden pošljete tiskalnik, škatlo označite z opozorilom »S TO STRANJO NAVZGOR«, da bo tiskalnik obrnjen s spodnjim delom navzdol. Označite tudi z oznako »LOMLJIVO« ali »RAVNAJTE PREVIDNO«.

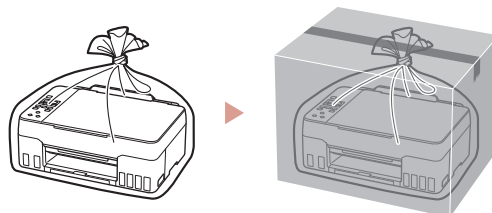

Postavljanje pisača



Za postavljanje posjetite URL

<https://ij.start.canon>



ili skenirajte kod svojim mobilnim uređajem

• Ako ne možete uspostaviti internetsku vezu, slijedite upute u nastavku.

1. Sadržaj kutije

• Ispisne glave

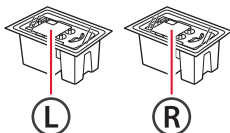

- Bočice tinte
- Kabel za napajanje
- CD-ROM za postavu
- Sigurnosne i važne informacije
- Početak (ovaj priručnik)

2. Uklanjanje ambalaže



- 1 Uklonite i odložite svu ambalažu i narančastu traku.
- 2 Otvorite jedinicu za skeniranje / poklopac, uklonite i odložite narančastu traku i zaštitni materijal u uređaju.

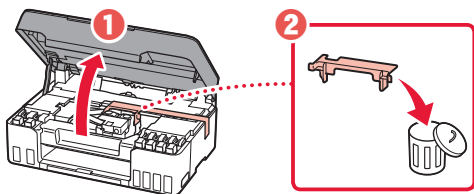

3. Postavljanje ispisnih glava



- 1 Otvorite poklopac za zaključavanje ispisne glave.

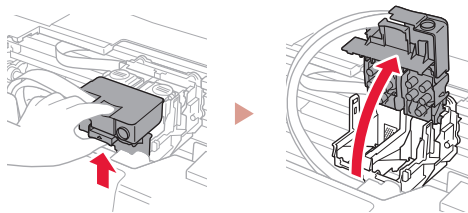

- 2 Izvadite iz paketa svaku ispisnu glavu i uklonite naljepnicu.

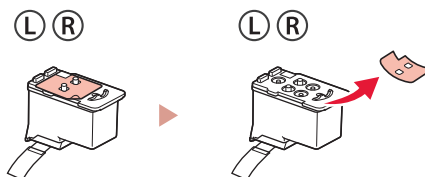

- 3 Skinite narančastu traku.

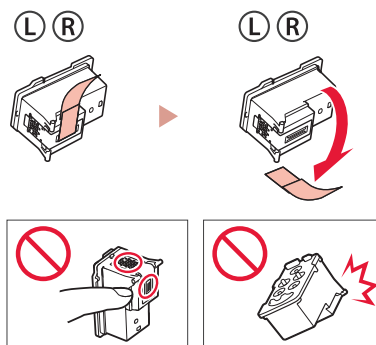

Postavljanje pisača

- 4 Umetnite L ispisnu glavu na lijevu stranu i R ispisnu glavu na desnu stranu.

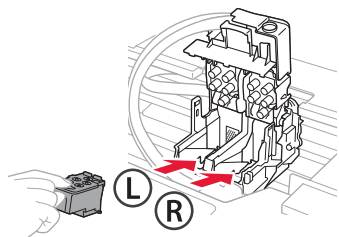

- 5 Zatvorite poklopac za zaključavanje ispisne glave i pritisnite prema dolje dok ne sjedne na mjesto.

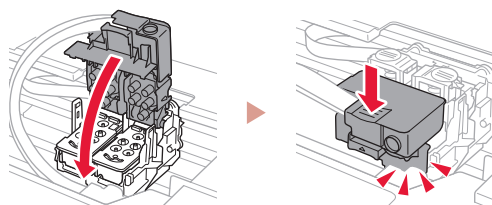

- 6 Pritisnite do kraja oba spojna gumba dok ne sjednu na mjesto.

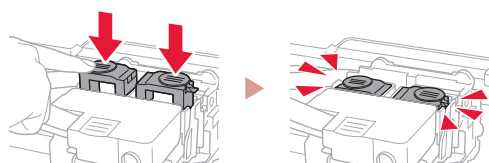

Provjerite!



- 7 Zatvorite jedinicu za skeniranje / poklopac.
- Otvorite jedinicu za skeniranje / poklopac do kraja pa ih zatvorite.

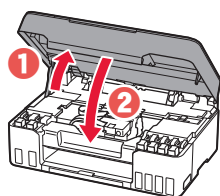

▲ Oprez
Pripazite na prste.

4. Uključivanje pisača



- 1 Povežite kabel za napajanje.

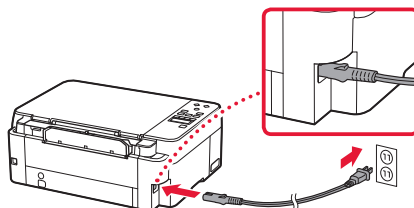

Zadnja stranica

- 2 Pritisnite gumb **UKLJUČENO (ON)**.

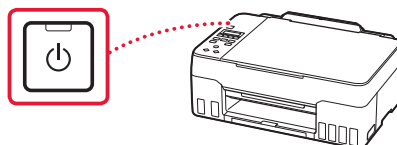

- 3 Kada se prikaže sljedeći zaslon, pomoću gumba ◀ i ▶ odaberite jezik pa pritisnite gumb **U redu (OK)**.



»»» Važno

Ako se na zaslonu pojavi pogreška, pogledajte „Ako se na zaslonu prikaže poruka o pogrešci (kôd za podršku)” na stranici 5 i slijedite upute.

5. Ulijevanje tinte



»»» Važno

Taj proizvod zahtijeva oprezno rukovanje tintom. Tinta može prskati kad su spremnici tinte ispunjeni tintom. Ako tintom zamrljate odjeću ili predmete, možda ih nećete moći oprati.

- 1 Otvorite jedinicu za skeniranje / poklopac.

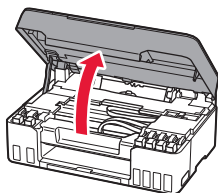

- 2 Otvorite sivu kapicu spremnika na lijevoj strani pisača.

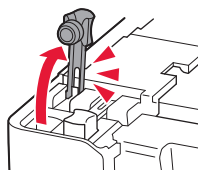

- 3 Uspravno držite GY (sivu) bočicu tinte i lagano okrenite kapicu bočice da biste je uklonili.

Provjerite!

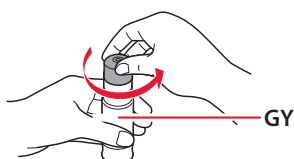

- 4 Poravnajte mlaznicu bočice tinte s ulaznim otvorom.

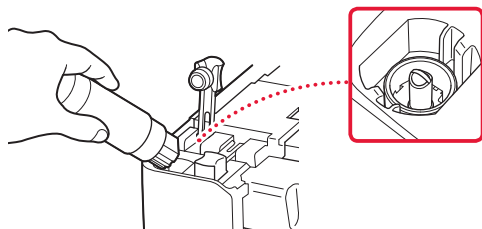

- 5 Polako postavite bočicu tinte naopako i gurnite je prema dolje za ulijevanje tinte.

- Ako se tinta ne ulije, polako uklonite bočicu tinte i pokušajte ponovno.

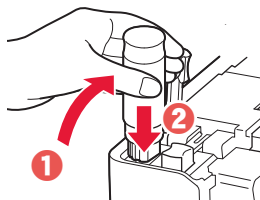

- 6 Polako uklonite bočicu tinte iz ulaznog otvora.

- Pazite da ne proljete tintu.

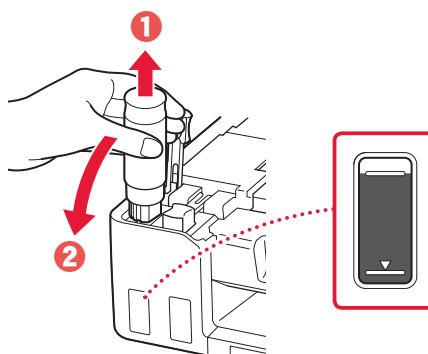

- 7 Zamijenite kapicu spremnika **na siguran način**.

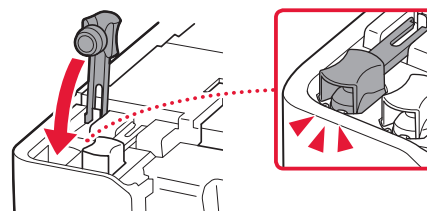

Postavljanje pisača

8 Ponovite korake od 2 do 7 za ulijevanje tinte za sve boje u spremnike tinte za svaku boju.

- Ulijte isporučenu tintu koja odgovara boji kapice spremnika.

Provjerite!

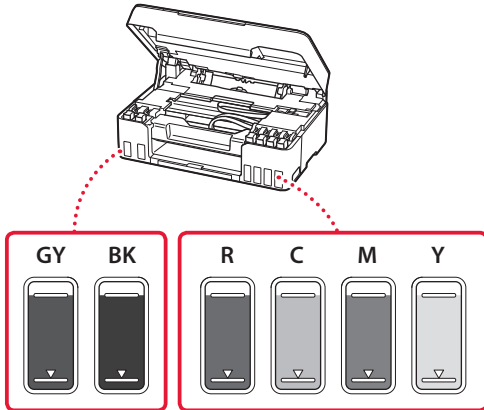

9 Zatvorite jedinicu za skeniranje / poklopac.

- Otvorite jedinicu za skeniranje / poklopac do kraja pa ih zatvorite.

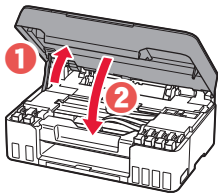

⚠ Oprez
Pripazite na prste.

10 Upotrijebite gumbе ◀ i ▶ kako biste odabrali **Da (Yes)**, a zatim pritisnite gumb **U redu (OK)**.

Are the ink tanks filled w
 Yes < No >

6. Umetanje papira



1 Upotrijebite gumbе ◀ i ▶ kako biste odabrali **Da (Yes)**, a zatim pritisnite gumb **U redu (OK)**.

Start alignment to impro
 Yes > No

2 Izvucite oslonac papira.

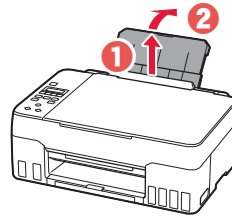

3 Otvorite poklopac otvora za ulaganje papira i povucite desnu vodilicu papira do kraja udesno.

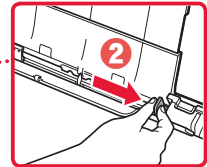
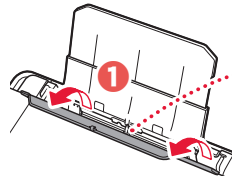

4 Umetnite papir.

- Umetnite 2 lista ili više listova običnog papira veličine Letter ili A4.
- Povucite bočnu vodilicu papira uz rub snopa papira.

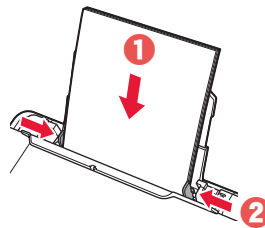

5 Zatvorite poklopac otvora za ulaganje papira.

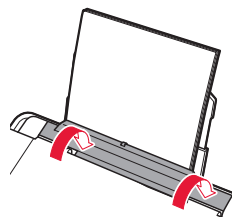

6 Izvucite ladicu za izlaz papira.

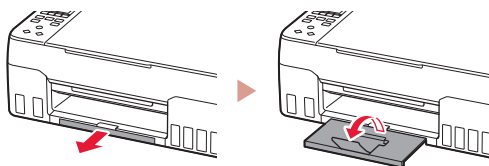

7 Slijedite upute na zaslonu pa pritisnite gumb **U redu (OK)**.

Load 2 or more sheets of
[OK]Next

Adjusting for first use...
About █ min. remaining

- Pričekajte da se prikaže sljedeći zaslon.

Do you want to update at
< Yes > No

Setup is complete
[OK]

To connect to a computer
[OK]

Copy
100% █ 01

Odaberite način povezivanja koji najbolje odgovara načinu na koji ćete upotrebljavati pišač.

- Za upotrebu pišača bez povezivanja s drugim uređajima
➔ Postavljanje je sada dovršeno.
- Za upotrebu pišača povezivanjem s računalom ili pametnim telefonom
➔ Prijedite na sljedeću stranicu.

? Ako se na zaslonu prikaže poruka o pogrešci (kôd za podršku)

Protective material rema
Support code 1890

Kôd za podrš.
(Support code)

Provjerite kôd za podršku, a zatim slijedite upute ako je prikazani kod zapisan u nastavku.

- 1890
Preostali zaštitni materijal.
➔ „2. Uklanjanje ambalaže“ na stranici 1
- 1470/1471
Ispisne glave nisu ispravno postavljene.
➔ „3. Postavljanje ispisnih glava“ na stranici 1
- 1474
Ispisne glave nisu ispravno postavljene.
Zatvorite ručicu ventila za tintu, te zamijenite lijevu i desnu ispisnu glavu.

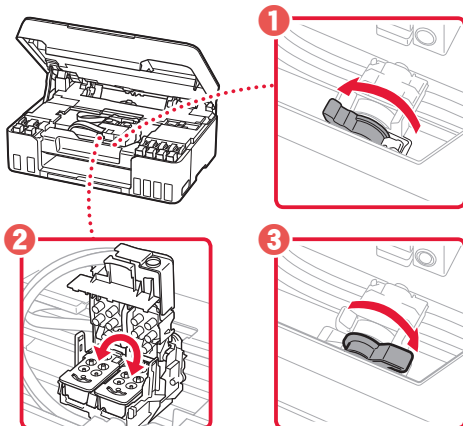

➔ „3. Postavljanje ispisnih glava“ na stranici 1

- 5200
Priprema sustava tinte nije uspješno dovršena.
Pritisnite gumb **UKLJUČENO (ON)** za ponovno pokretanje pišača, a zatim pogledajte „5. Uljevanje tinte“ na stranici 3.

Za sve druge slučajeve pogledajte **Priručnik na mreži**.

Koji uređaj spajate?



Računalo



Računalo i pametni telefon





Pametni telefon

7-a

Povezivanje s računalom

Ako koristite više od jednog računala, izvršite ove korake na svakom od njih.



- 1 Putem računala pristupite web-mjestu Canon.
 <https://ij.start.canon>
- 2 Odaberite  **Postavljanje**.
- 3 Unesite naziv modela svog pisača i kliknite **Kreni**.
- 4 Kliknite **Započni**.
- 5 Kliknite **(B) Povezivanje s računalom / pametnim telefonom**.
 - Sljedeći koraci namijenjeni su korisnicima sustava Windows.
- 6 Kliknite **Preuzmi**.
- 7 Pokrenite preuzetu datoteku.
 - Slijedite upute na zaslonu. To može malo potrajati.
 - Ako se želite povezati i s pametnim telefonom, pogledajte odjeljak „7-b. Povezivanje pametnog telefona“ na stranici 7.



Upotreba CD-ROM-a za postavu

U CD-ROM-u dvaput kliknite **EasySetup.exe**, a zatim nastavite od 3. koraka. Ako internetska veza nije uspostavljena, u CD-ROM-u otvorite mapu **win** i dvaput kliknite **SETUP.exe**. Time ćete instalirati upravljački program za pisač.

7-b

Povezivanje pametnog telefona

Ako koristite više od jednog pametnog telefona, izvršite ove korake na svakom od njih.



1 Instalirajte aplikaciju „Canon PRINT Inkjet/SELPHY“ na svoj pametni telefon.



- Potražite „Canon PRINT“ u trgovini App Store ili Google Play.
- Pristupite web-mjestu Canon kako biste preuzeli aplikaciju.



2 Otvorite postavke Wi-Fi na vašem pametnom telefonu. Provjerite prikazuje li se naziv mreže (SSID) koji počinje s „Canon_ij_“.

(Primjer zaslona uređaja sa sustavom iOS)

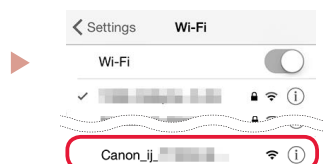

Naziv mreže (SSID) koji počinje s „Canon_ij_“

- Ako se prikaže „Canon_ij_“, → prijedite na korak **3**.
- Ako se „Canon_ij_“ ne prikaže, → prijedite na korak **4**.

3 Dodirnite naziv mreže (SSID) koji počinje s „Canon_ij_“.

4 Otvorite instaliranu aplikaciju pa slijedite upute na zaslonu u aplikaciji za dodavanje pisača.



Nakon što dodate pisač, moći ćete ispisivati s pametnog telefona.
Za ispis fotografija pogledajte „Umetanje fotopapira“ na stranici 8.

Umetanje fotopapira

1 Izvucite oslonac papira.

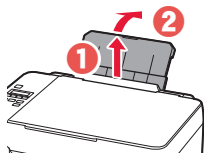

2 Otvorite poklopac otvora za ulaganje papira i povucite desnu vodilicu papira do kraja udesno.

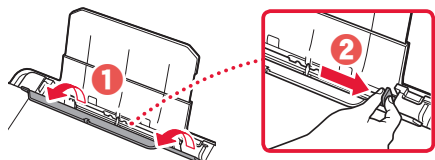

3 Umetnite nekoliko listova fotopapira sa stranom za ispis okrenutom prema gore i povucite bočnu vodilicu papira uz rub snopa papira.

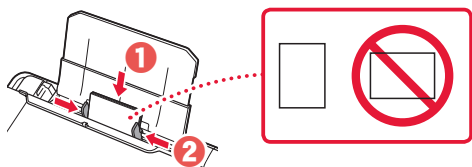

4 Zatvorite poklopac otvora za ulaganje papira.

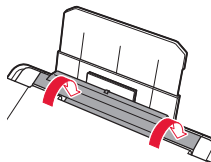

5 Kad se poruka **Registrirajte podatke o papiru u stražnjoj ladici (Save the rear tray paper information)** pojavi na zaslonu pisača, pritisnite gumb **U redu (OK)**.

6 Odaberite veličinu i vrstu papira, a zatim pritisnite gumb **U redu (OK)**.

7 Izvucite ladicu za izlaz papira.

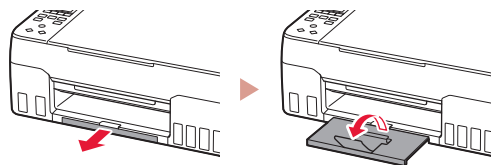

Prijenos pisača

Kod premještanja pisača provjerite sljedeće. Za pojedinosti pogledajte **Priručnik na mreži**.

Provjerite jesu li oba spojna gumba do kraja pritisnuta kako biste izbjegli curenje tinte.

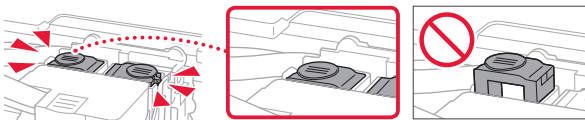

Pazite da je ručica ventila za tintu u zatvorenom položaju.

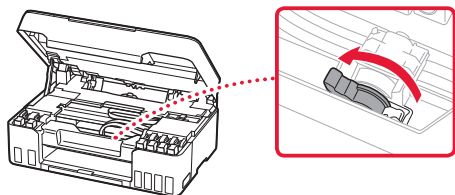

U slučaju curenja tinte spakirajte pisač u plastičnu vrećicu.

- Spakirajte pisač u čvrstu kutiju tako da donji dio bude okrenut prema dolje i upotrijebite dovoljno zaštitnog materijala da bi prijevoz bio siguran.
- Ne nagnjite pisač. Može doći do curenja tinte.
- Pažljivo rukujte kutijom i pobrinite se da ostane na ravnom te je NE okrećite naopako ili na stranu jer se pisač može oštetiti, a tinta može iscuriti iz pisača.
- Ako kurir obavlja prijevoz pisača, na kutiji označite „GORNJA STRANA” da ne bi okretao pisač naopako. Stavite i oznake „OSJETLJIVO” ili „PAŽLJIVO RUKOVATI”.

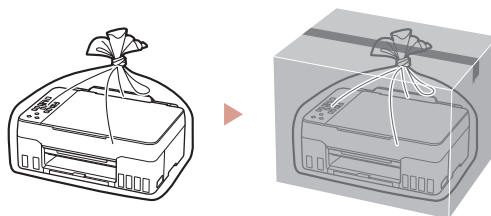

Εμπορικά σήματα

- Η επωνυμία Windows είναι εμπορικό σήμα ή σήμα κατατεθέν της Microsoft Corporation στις Η.Π.Α. ή/και σε άλλες χώρες.
- App Store είναι εμπορικό σήμα της Apple Inc., καταχωρημένα στις ΗΠΑ και σε άλλες χώρες.
- Το Google Play είναι σήμα κατατεθέν της Google LLC.

Ochranné známky

- Windows je ochranná známka nebo registrovaná ochranná známka společnosti Microsoft Corporation v USA a dalších zemích.
- App Store je ochrannou známkou společnosti Apple Inc. registrované v USA a dalších zemích.
- Google Play je ochrannou známkou společnosti Google LLC.

Ochranné známky

- Windows je ochranná známka alebo registrovaná ochranná známka spoločnosti Microsoft Corporation v USA alebo iných krajinách.
- App Store je ochranná známka spoločnosti Apple Inc. registrované v USA a iných krajinách.
- Google Play je ochranná známka spoločnosti Google LLC.

Znaki towarowe

- Windows jest znakiem towarowym lub zastrzeżonym znakiem towarowym firmy Microsoft Corporation na terenie Stanów Zjednoczonych lub innych krajów.
- App Store jest znakiem towarowym firmy Apple Inc. zastrzeżonymi na terenie Stanów Zjednoczonych i innych krajów.
- Google Play jest zastrzeżonym znakiem towarowym Google LLC.

Védjegyek

- A Windows a Microsoft Corporation Egyesült Államokban és/vagy más országokban bejegyzett védjegye.
- Az App Store az Apple Inc. bejegyzett védjegye az Amerikai Egyesült Államokban és más országokban.
- A Google Play a Google LLC bejegyzett védjegye.

Ticari Markalar

- Windows, ABD'de ve/veya diğer ülkelerde bir Microsoft Corporation markası veya tescilli markasıdır.
- App Store, Apple Inc. şirketinin ABD ve diğer ülkelerdeki tescilli ticari markalarıdır.
- Google Play, Google LLC şirketinin tescilli ticari markasıdır.

Mărci comerciale

- Windows este marcă comercială sau marcă comercială înregistrată a Microsoft Corporation în S.U.A. și/sau alte țări.
- App Store este o marcă comercială a Apple Inc., înregistrată în S.U.A. și în alte țări.
- Google Play este o marcă comercială înregistrată a Google LLC.

Търговски марки

- Windows е търговска марка или регистрирана търговска марка на Microsoft Corporation в САЩ и/или други страни.
- App Store е търговска марка на Apple Inc., регистрирани в САЩ и други държави.
- Google Play е регистрирана търговска марка на Google LLC.

Blagovne znamke

- Windows je blagovna znamka ali zaščitena blagovna znamka družbe Microsoft Corporation v ZDA in/ali drugih državah.
- App Store je blagovna znamka družbe Apple Inc., registrirane v ZDA in drugih državah.
- Google Play je zaščitena blagovna znamka družbe Google LLC.

Robni žigovi

- Windows robni je žig ili registrirani robni žig tvrtke Microsoft Corporation u SAD-u i/ili drugim državama.
- App Store je robni žig tvrtke Apple Inc. registriran u SAD-u i drugim državama.
- Google Play je registrirani robni žig tvrtke Google LLC.



Αποκτήστε πρόσβαση στο Εγχειρίδιο Online
Prístup k dokumentu Průručka online
Hogyan érhető el az Online kézikönyv
Accesati Manual online
Odprite Spletni priročnik

Přečtete si dokument Průručka online
Pobierz Podręcznik online
Çevrimiçi El Kitabı'na erişme
Достъп до Онлайн ръководство
Pristupite dokumentu Priručnik na mreži

Από το πρόγραμμα περιήγησής σας

Pomocí webového prohlížeče

Cez webový prehliadač

Z przeglądarki

Böngészőből

Tarayıcınızdan

Din browser

От браузър

Prek brskalnika

Iz svog preglednika

